

AMHS Solution for

Semiconductor Smart Manufacturing



Gyromatic / Gyrobot / Gyro

(Singapore / China / Taiwan)

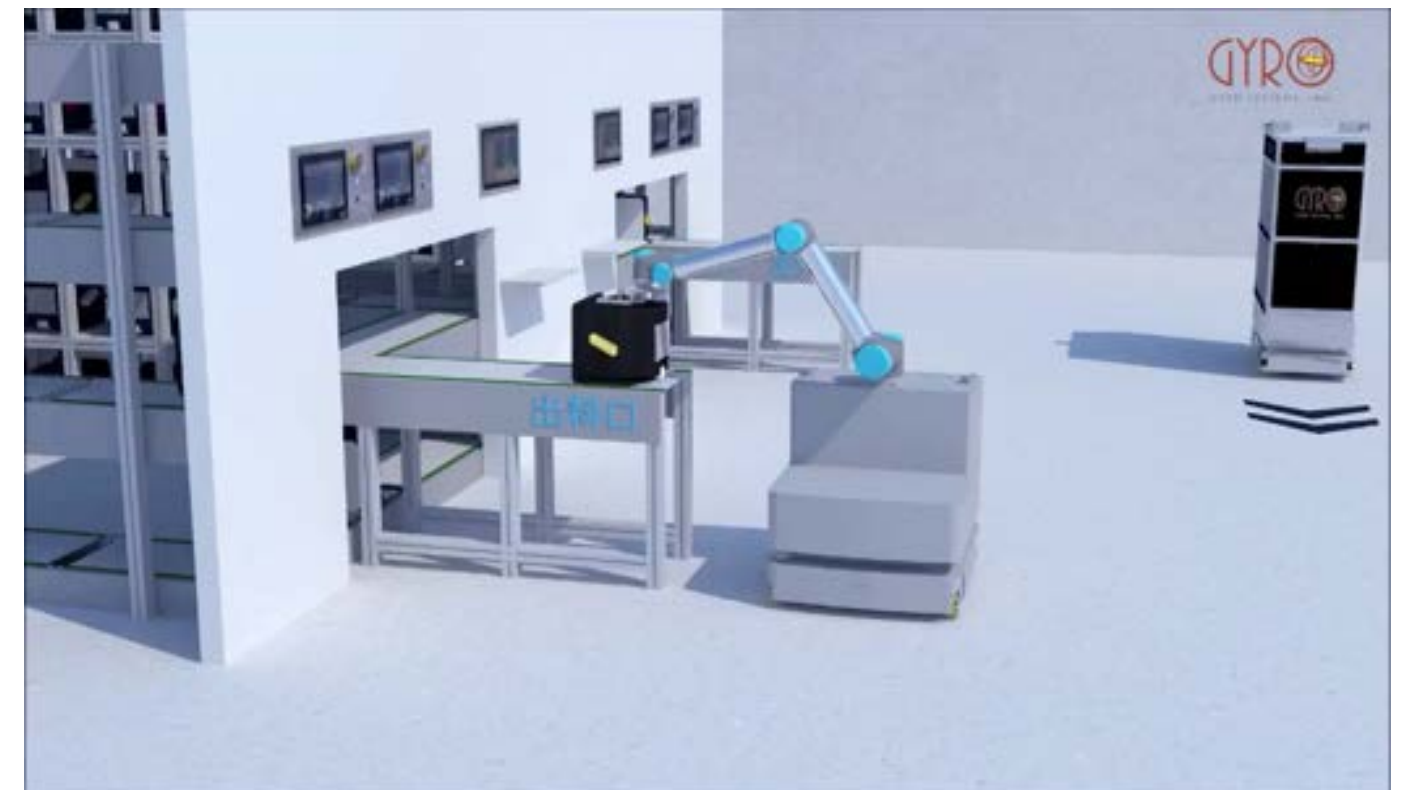



Contents

- 01 | Company introduction**
- 02 | Products introduction**
- 03 | System Introduction and Services**
- 04 | Product Details**
- 05 | Application and safety**



PART 1

Company Introduction

- **Company introduction**
- **Products and services**
- **Gyrobot Global Support**
- **Gyro AMHS Total Solution**
- **Gyro Advantages**

Company Introduction

- 2025 Gyro new assembly site in Maur, Malaysia
- 2024 Gyro System Technology (Osaka) Limited
- 2023 Kaohsiung Office Established
- 2022 North American Sales Agency
- 2021 Singapore Service Center Established
- 2020 Second Factory in Hsinchu Established
- 2019 Suzhou Factory Established,
China Customer Service/Sales Team Formed
- 2018 Hsin-Chu Factory Established
- 2015 Founded at National Tsing Hua University

Innovation Incubation Center



11

Service Locations



35 M

Capital (USD)



10 y

Establishment History



140+

Business Partners



60+

Factory installed base



100+

Projects

Gyro AMHS Total Solution For Smart

Semiconductor Factory (Field proven in >60 factories) System

AMHS:
Advanced **M**aterial **H**andling
System

AMR:
Autonomous
Mobile
Robot

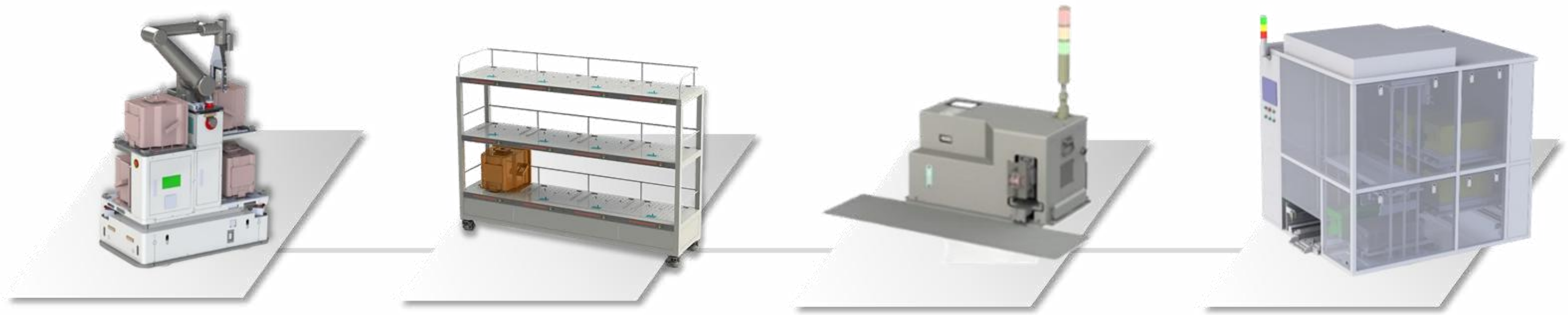

AMR

E-Rack

Charging Station

Automatic Battery
Change System

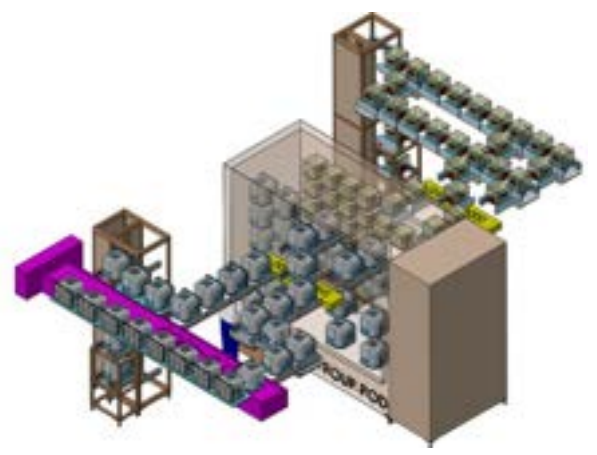

OHCV

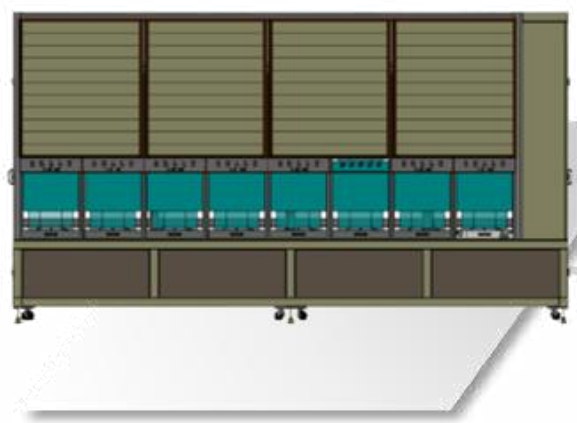

Stocker

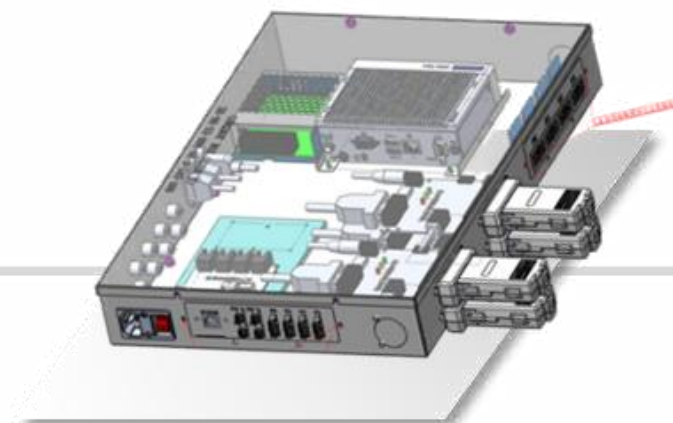

E84 solution



Smart TAG/LF/UHF
RFID reader



Gyro Software
MCS/TSC/AGVC...

Gyro Customer List (partial only)

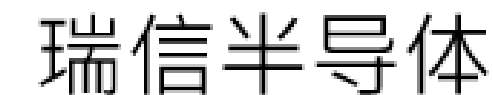
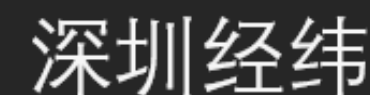

GYRO Customer Locations

GYRO



Achievement

Global Market Presence

Established Markets :

Taiwan, China, Singapore

Growing Markets :

Japan

Malaysia

US

Europe

Mexico

Thailand

Korea

India

Regional Customer Portfolio

Taiwan

ASE, SPIL, PTI, UMC, TSMC, Formosa, Sumco, KYEC, Chipmos, Teraprobe, Amkor

China

JCET, JCAP, TFME, Nexchip, SJSemi, HH Grace, BOE, BMOT, BAWIN, TI, SPIL, Renesas

Singapore

JCET/StatsChipPac, RF360/Qualcomm, UTAC, Skyworks, UMC, IME, Micron, GF (POC)

Japan

Skyworks, Renesas, TI, TeraProbe

US

TI, Skyworks, Intel

Malaysia

Renesas, TI, ASE, Infineon, Denzo

Europe

ST Micro –Malta, Crolles

Thailand

Analog

Mexico

Skyworks

Gyro has successfully developed global business with Skyworks, Renesas, TI with upcoming STM, Intel and Micron global sites too

GYRO Worldwide Support



Worldwide Support

Country	R&D	Manufacture	FAE Support	Spare Part	SI Partner
Singapore	V		V	V	
China	V	V	V	V	
Taiwan	V	V	V	V	
Malaysia		V	V	V	Solid Point
Philippines			V	V	JB-elite
Thailand			V	V	JB-elite
US			V	V	Maven Global Partners
Japan			V	V	
Mexico			V	V	
EU			V	V	4JMSolution
Korea			V	V	Daeryu SMA
India			V	V	Unimark

Content of FAE Service and Support

- SLAM map mapping
- Station setting(Macro-based)
- Route map planning
- Robot Arm performance optimization
- AMR Software modification
- AGVC system software interface/integration
- MCS system software interface/integration
- E84 signal hand-shaking and optimization
- AGV motion parameter optimization
- AGV hardware check/repair/fixing

Organisation

Manufacturing capacity for AMR/month

Taiwan – 40/month
 Suzhou - 60/month
 Malaysia - 10 by Dec 2025

Manufacturing capacity for eRack

Taiwan - 60
 Suzhou - 120
 Malaysia - 60 (by Dec 25)

Manufacturing capacity for Stocker

Taiwan - 4
 Suzhou - 5

Sales, Project Manager and FSE

S&PM: 16, FAE:100
 Sale Rep - USA, Philippines, Malta, Germany, Korea, India

R&D

Software: 30
 Ind. 4.0: 8
 Intelligent Robot: 5
 HW Design: 30

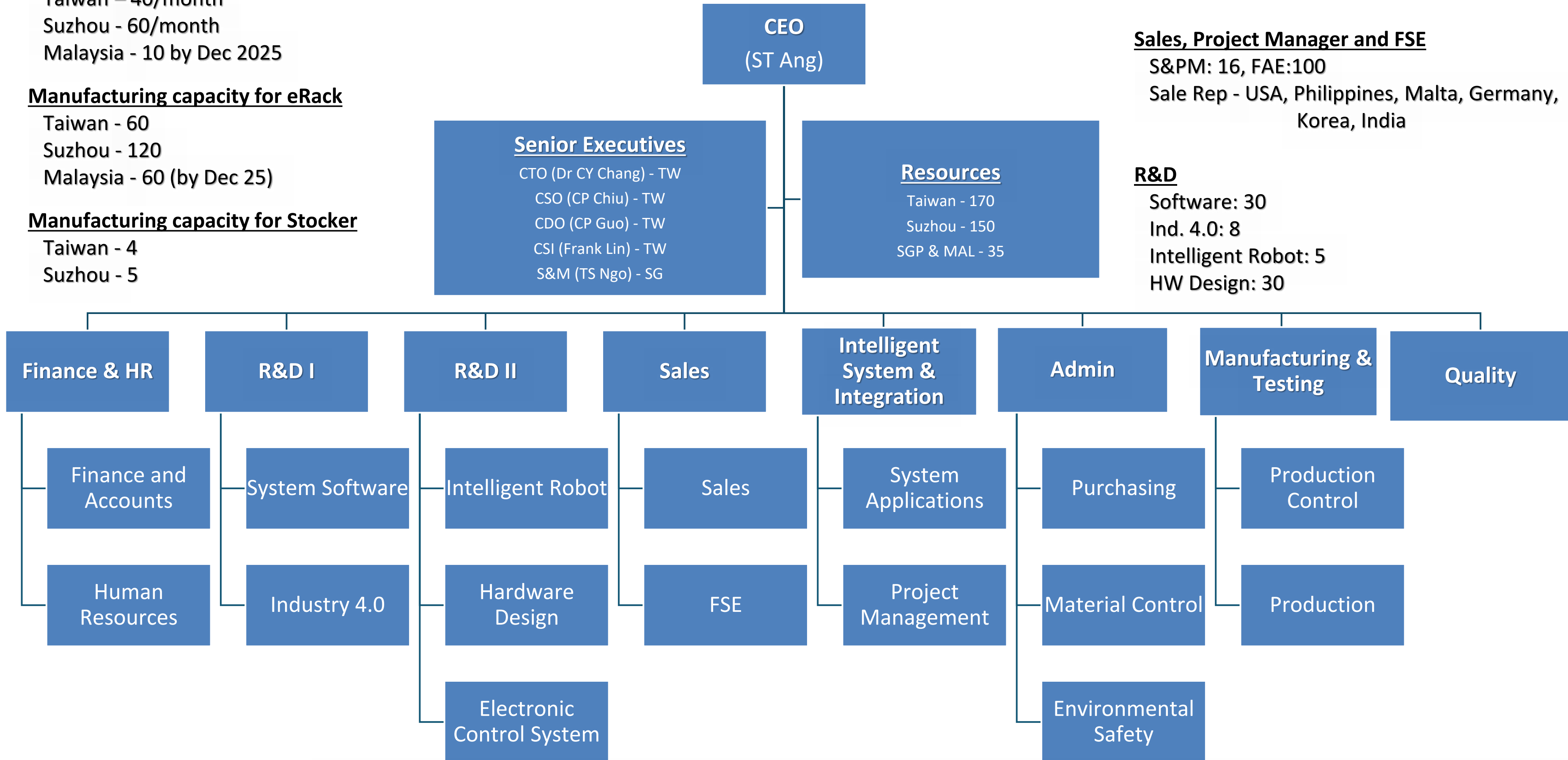

Sales and Service coverage: Singapore, Taiwan, Japan, China, Malaysia, Philippines, Thailand, Germany, Malta, USA, Mexico, Korea, India

AMR Fabrication, Assembly and Test (TW/CN/MY)



Gyro Advantages

AMR payload 30Kg

AMR

Corresponding to various kind of carrier:
12"FOUP / 8"open CST / Magazine /JEDEC Tray
AI-Image processing for Robot with 12~30 Kg payload

Mecanum Wheel

Four-Mecanum wheel

Forward/Backward/side-shift/rotate – in any direction.
AI-self learning movement

Navigation

SLAM map scan

AI-enhanced smart navigation
AI-assisted obstacle detection and safety

Safety/Reliability

Multi safety sensors (protections)

Safety sensor, Area Sensor, Bumper, Lidar scan, IR sensor, supersonic sensor.

Integration/Smart

Independent development systems

EAP, MCS, AGV-Controller, E-rack-Controller, Stocker-Controller, RTD. Highly integration, truly smart

Core Competencies

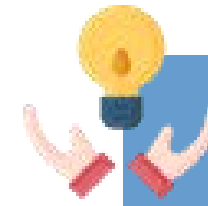

Local R&D

Complete local design and manufacturing
– Not outsourced
All software systems developed in-house
– Not outsourced



Software & Hardware Integration

MCS/AGVC/AGV/E84/RFID
- fully self-developed
High-integration, single interface



Premium Service

Comprehensive warranty,
high-customization
Complete service team, integrated from R&D
to on-site support

PART 2

Products introduction

- **AMR Safety and Stability**
- **AMR Certification**
- **Gyro Simulation Analysis Service**
- **Product List**



AMR Safety and Stability

- No blind spots in navigation positioning / safety detection
- Secondary body positioning – Omnidirectional wheels/visual precise alignment
- Robotic arm 2.5D vision – 6 degrees of freedom coordinate calibration

Key Components for Stability/Flexibility/Efficiency



Four-wheel direct drive omnidirectional wheels

2.5D positioning camera

3D camera

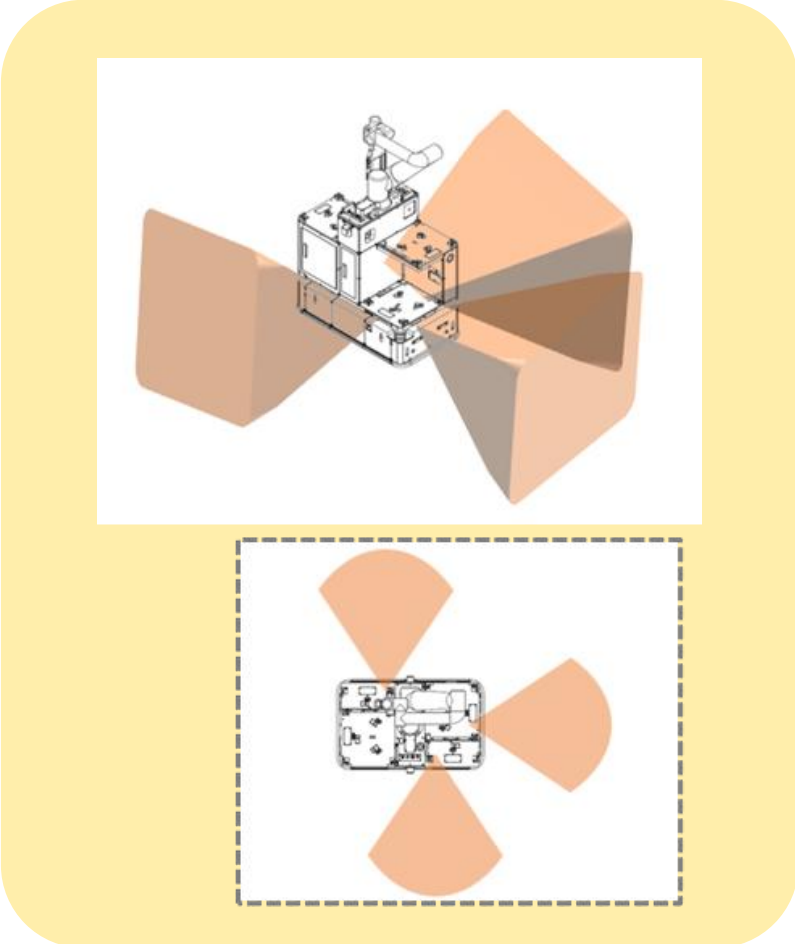

Vertical laser

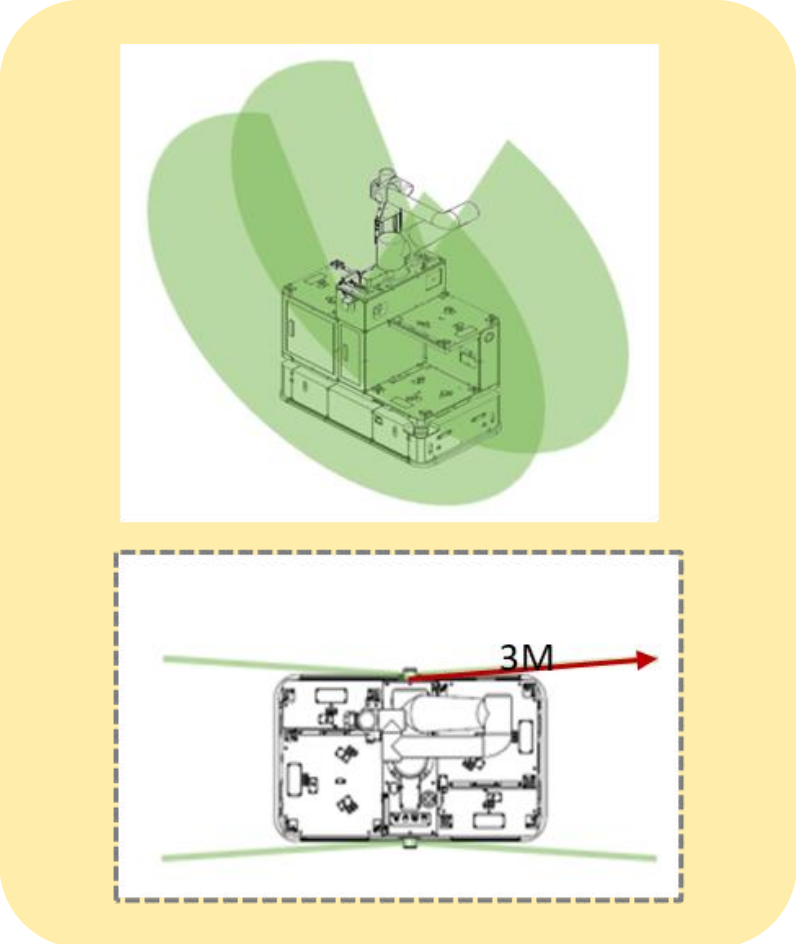

Horizontal laser

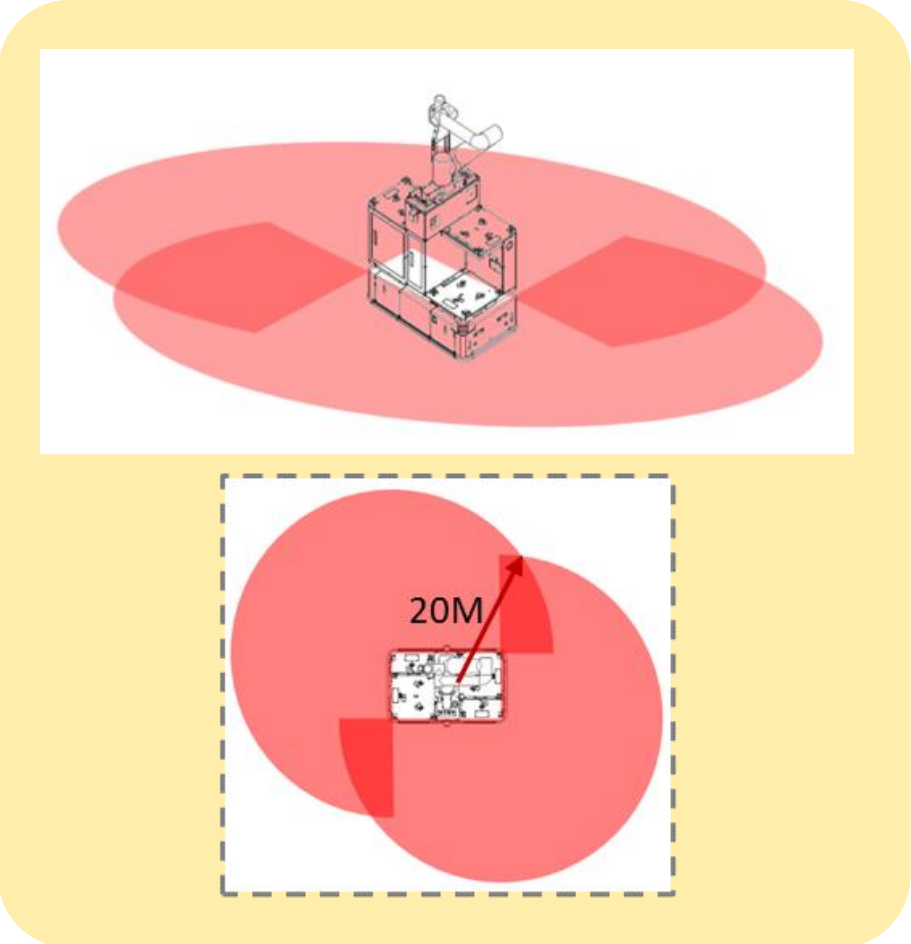

AMR Certification



Priority on Personnel/Product/Equipment Safety

SEMI-S2 Environmental, Health, and Safety Guideline for Semiconductor Manufacturing Equipment

SEMI-S14 Fire Risk Assessment and Mitigation for Semiconductor Manufacturing Equipment

SEMI-S8 Ergonomics Engineering of Semiconductor Manufacturing Equipment

SEMI-S17 Unmanned Transport Vehicle (UTV) Systems

SEMI-S10 Risk Assessment and Risk Evaluation Process

SEMI-S22 the Electrical Design of Semiconductor Manufacturing Equipment

SEMI-S13 Documents Provided to the Equipment User for Use With Manufacturing Equipment

6-axis Collaborative Robot

ISO 10218-1 and ISO 15066

Human-Robot Collaboration International Standard Certification



GRYO AMR HAS ATTACHED CERTIFICATION OF CONFIRMITY .
AGV with Robot (model : AMRA04) overall result are conforming the requirements for particle emission cleanroom ISO 3 standard (Class 1)

	0.5 µm	0.5 µm	1.0 µm	2.0 µm	5.0 µm	
Class 1	35	7.5	3	1	NA	ISO 3
Class 10	350	75	30	10	NA	ISO 4
Class 100	NA	750	300	100	NA	ISO 5
Class 1,000	NA	NA	NA	1,000	7	ISO 6
Class 10,000	NA	NA	NA	10,000	70	ISO 7
Class 100,000	NA	NA	NA	100,000	700	ISO 8

SGS Certificate of Conformity
The Certificate of Conformity is for the Autonomous Mobile Robot model AMRA04 produced by Gyro Technology (Shouho) Co., Ltd.
Certification Number: CoC 9951424000000201
Certification issue date: 2024-01-25
Valid period: 2027-01-25
Reference Test Report: 02.20240105001
Applicant: Gyro Technology (Shouho) Co., Ltd.
Address: West A, 5th Floor, Building 3, Wuhoung District, Suzhou
Type of product: Autonomous Mobile Robot
Model/Type: AMRA04
Trademark: GYRO

PMC SEMI S2 Certificate of Compliance
Precision Machinery Research & Development Center
Voluntary Examination of Technical File for compliance with the requirements of SEMI Environmental, Health, and Safety Guideline S2-0818 relating to semiconductor manufacturing equipment.
Issued to: Gyro Systems, Inc.
Address: No. 3, Ln. 179, Xinhou Rd, Zhushan City, Hainan County, 302
TEL: 022581-3598

TM Robot

ISO 10218-1

SGS CERTIFICATE OF COMPLIANCE
Certificate No. MOC 2889
ISO Reference: C972000041
Date of Issue: 04th May 2018
Class/Applicant: TECHNAN ROBOT INC.
Manufacturer: As above
Scope of certification: Full technical file assessment according to Annex VI 2006/42/EC
Department of Equipment: Industrial Robot
Type/series: TM1700, TM1800, TM1900, TM2000, TM2100, TM2200, TM2300, TM2400, TM2500, TM2600, TM2700, TM2800, TM2900, TM3000, TM3100, TM3200, TM3300, TM3400, TM3500, TM3600, TM3700, TM3800, TM3900, TM4000, TM4100, TM4200, TM4300, TM4400, TM4500, TM4600, TM4700, TM4800, TM4900, TM5000, TM5100, TM5200, TM5300, TM5400, TM5500, TM5600, TM5700, TM5800, TM5900, TM6000, TM6100, TM6200, TM6300, TM6400, TM6500, TM6600, TM6700, TM6800, TM6900, TM7000, TM7100, TM7200, TM7300, TM7400, TM7500, TM7600, TM7700, TM7800, TM7900, TM8000, TM8100, TM8200, TM8300, TM8400, TM8500, TM8600, TM8700, TM8800, TM8900, TM9000, TM9100, TM9200, TM9300, TM9400, TM9500, TM9600, TM9700, TM9800, TM9900, TM10000, TM10100, TM10200, TM10300, TM10400, TM10500, TM10600, TM10700, TM10800, TM10900, TM11000, TM11100, TM11200, TM11300, TM11400, TM11500, TM11600, TM11700, TM11800, TM11900, TM12000, TM12100, TM12200, TM12300, TM12400, TM12500, TM12600, TM12700, TM12800, TM12900, TM13000, TM13100, TM13200, TM13300, TM13400, TM13500, TM13600, TM13700, TM13800, TM13900, TM14000, TM14100, TM14200, TM14300, TM14400, TM14500, TM14600, TM14700, TM14800, TM14900, TM15000, TM15100, TM15200, TM15300, TM15400, TM15500, TM15600, TM15700, TM15800, TM15900, TM16000, TM16100, TM16200, TM16300, TM16400, TM16500, TM16600, TM16700, TM16800, TM16900, TM17000, TM17100, TM17200, TM17300, TM17400, TM17500, TM17600, TM17700, TM17800, TM17900, TM18000, TM18100, TM18200, TM18300, TM18400, TM18500, TM18600, TM18700, TM18800, TM18900, TM19000, TM19100, TM19200, TM19300, TM19400, TM19500, TM19600, TM19700, TM19800, TM19900, TM20000, TM20100, TM20200, TM20300, TM20400, TM20500, TM20600, TM20700, TM20800, TM20900, TM21000, TM21100, TM21200, TM21300, TM21400, TM21500, TM21600, TM21700, TM21800, TM21900, TM22000, TM22100, TM22200, TM22300, TM22400, TM22500, TM22600, TM22700, TM22800, TM22900, TM23000, TM23100, TM23200, TM23300, TM23400, TM23500, TM23600, TM23700, TM23800, TM23900, TM24000, TM24100, TM24200, TM24300, TM24400, TM24500, TM24600, TM24700, TM24800, TM24900, TM25000, TM25100, TM25200, TM25300, TM25400, TM25500, TM25600, TM25700, TM25800, TM25900, TM26000, TM26100, TM26200, TM26300, TM26400, TM26500, TM26600, TM26700, TM26800, TM26900, TM27000, TM27100, TM27200, TM27300, TM27400, TM27500, TM27600, TM27700, TM27800, TM27900, TM28000, TM28100, TM28200, TM28300, TM28400, TM28500, TM28600, TM28700, TM28800, TM28900, TM29000, TM29100, TM29200, TM29300, TM29400, TM29500, TM29600, TM29700, TM29800, TM29900, TM30000, TM30100, TM30200, TM30300, TM30400, TM30500, TM30600, TM30700, TM30800, TM30900, TM31000, TM31100, TM31200, TM31300, TM31400, TM31500, TM31600, TM31700, TM31800, TM31900, TM32000, TM32100, TM32200, TM32300, TM32400, TM32500, TM32600, TM32700, TM32800, TM32900, TM33000, TM33100, TM33200, TM33300, TM33400, TM33500, TM33600, TM33700, TM33800, TM33900, TM34000, TM34100, TM34200, TM34300, TM34400, TM34500, TM34600, TM34700, TM34800, TM34900, TM35000, TM35100, TM35200, TM35300, TM35400, TM35500, TM35600, TM35700, TM35800, TM35900, TM36000, TM36100, TM36200, TM36300, TM36400, TM36500, TM36600, TM36700, TM36800, TM36900, TM37000, TM37100, TM37200, TM37300, TM37400, TM37500, TM37600, TM37700, TM37800, TM37900, TM38000, TM38100, TM38200, TM38300, TM38400, TM38500, TM38600, TM38700, TM38800, TM38900, TM39000, TM39100, TM39200, TM39300, TM39400, TM39500, TM39600, TM39700, TM39800, TM39900, TM40000, TM40100, TM40200, TM40300, TM40400, TM40500, TM40600, TM40700, TM40800, TM40900, TM41000, TM41100, TM41200, TM41300, TM41400, TM41500, TM41600, TM41700, TM41800, TM41900, TM42000, TM42100, TM42200, TM42300, TM42400, TM42500, TM42600, TM42700, TM42800, TM42900, TM43000, TM43100, TM43200, TM43300, TM43400, TM43500, TM43600, TM43700, TM43800, TM43900, TM44000, TM44100, TM44200, TM44300, TM44400, TM44500, TM44600, TM44700, TM44800, TM44900, TM45000, TM45100, TM45200, TM45300, TM45400, TM45500, TM45600, TM45700, TM45800, TM45900, TM46000, TM46100, TM46200, TM46300, TM46400, TM46500, TM46600, TM46700, TM46800, TM46900, TM47000, TM47100, TM47200, TM47300, TM47400, TM47500, TM47600, TM47700, TM47800, TM47900, TM48000, TM48100, TM48200, TM48300, TM48400, TM48500, TM48600, TM48700, TM48800, TM48900, TM49000, TM49100, TM49200, TM49300, TM49400, TM49500, TM49600, TM49700, TM49800, TM49900, TM50000, TM50100, TM50200, TM50300, TM50400, TM50500, TM50600, TM50700, TM50800, TM50900, TM51000, TM51100, TM51200, TM51300, TM51400, TM51500, TM51600, TM51700, TM51800, TM51900, TM52000, TM52100, TM52200, TM52300, TM52400, TM52500, TM52600, TM52700, TM52800, TM52900, TM53000, TM53100, TM53200, TM53300, TM53400, TM53500, TM53600, TM53700, TM53800, TM53900, TM54000, TM54100, TM54200, TM54300, TM54400, TM54500, TM54600, TM54700, TM54800, TM54900, TM55000, TM55100, TM55200, TM55300, TM55400, TM55500, TM55600, TM55700, TM55800, TM55900, TM56000, TM56100, TM56200, TM56300, TM56400, TM56500, TM56600, TM56700, TM56800, TM56900, TM57000, TM57100, TM57200, TM57300, TM57400, TM57500, TM57600, TM57700, TM57800, TM57900, TM58000, TM58100, TM58200, TM58300, TM58400, TM58500, TM58600, TM58700, TM58800, TM58900, TM59000, TM59100, TM59200, TM59300, TM59400, TM59500, TM59600, TM59700, TM59800, TM59900, TM60000, TM60100, TM60200, TM60300, TM60400, TM60500, TM60600, TM60700, TM60800, TM60900, TM61000, TM61100, TM61200, TM61300, TM61400, TM61500, TM61600, TM61700, TM61800, TM61900, TM62000, TM62100, TM62200, TM62300, TM62400, TM62500, TM62600, TM62700, TM62800, TM62900, TM63000, TM63100, TM63200, TM63300, TM63400, TM63500, TM63600, TM63700, TM63800, TM63900, TM64000, TM64100, TM64200, TM64300, TM64400, TM64500, TM64600, TM64700, TM64800, TM64900, TM65000, TM65100, TM65200, TM65300, TM65400, TM65500, TM65600, TM65700, TM65800, TM65900, TM66000, TM66100, TM66200, TM66300, TM66400, TM66500, TM66600, TM66700, TM66800, TM66900, TM67000, TM67100, TM67200, TM67300, TM67400, TM67500, TM67600, TM67700, TM67800, TM67900, TM68000, TM68100, TM68200, TM68300, TM68400, TM68500, TM68600, TM68700, TM68800, TM68900, TM69000, TM69100, TM69200, TM69300, TM69400, TM69500, TM69600, TM69700, TM69800, TM69900, TM70000, TM70100, TM70200, TM70300, TM70400, TM70500, TM70600, TM70700, TM70800, TM70900, TM71000, TM71100, TM71200, TM71300, TM71400, TM71500, TM71600, TM71700, TM71800, TM71900, TM72000, TM72100, TM72200, TM72300, TM72400, TM72500, TM72600, TM72700, TM72800, TM72900, TM73000, TM73100, TM73200, TM73300, TM73400, TM73500, TM73600, TM73700, TM73800, TM73900, TM74000, TM74100, TM74200, TM74300, TM74400, TM74500, TM74600, TM74700, TM74800, TM74900, TM75000, TM75100, TM75200, TM75300, TM75400, TM75500, TM75600, TM75700, TM75800, TM75900, TM76000, TM76100, TM76200, TM76300, TM76400, TM76500, TM76600, TM76700, TM76800, TM76900, TM77000, TM77100, TM77200, TM77300, TM77400, TM77500, TM77600, TM77700, TM77800, TM77900, TM78000, TM78100, TM78200, TM78300, TM78400, TM78500, TM78600, TM78700, TM78800, TM78900, TM79000, TM79100, TM79200, TM79300, TM79400, TM79500, TM79600, TM79700, TM79800, TM79900, TM80000, TM80100, TM80200, TM80300, TM80400, TM80500, TM80600, TM80700, TM80800, TM80900, TM81000, TM81100, TM81200, TM81300, TM81400, TM81500, TM81600, TM81700, TM81800, TM81900, TM82000, TM82100, TM82200, TM82300, TM82400, TM82500, TM82600, TM82700, TM82800, TM82900, TM83000, TM83100, TM83200, TM83300, TM83400, TM83500, TM83600, TM83700, TM83800, TM83900, TM84000, TM84100, TM84200, TM84300, TM84400, TM84500, TM84600, TM84700, TM84800, TM84900, TM85000, TM85100, TM85200, TM85300, TM85400, TM85500, TM85600, TM85700, TM85800, TM85900, TM86000, TM86100, TM86200, TM86300, TM86400, TM86500, TM86600, TM86700, TM86800, TM86900, TM87000, TM87100, TM87200, TM87300, TM87400, TM87500, TM87600, TM87700, TM87800, TM87900, TM88000, TM88100, TM88200, TM88300, TM88400, TM88500, TM88600, TM88700, TM88800, TM88900, TM89000, TM89100, TM89200, TM89300, TM89400, TM89500, TM89600, TM89700, TM89800, TM89900, TM90000, TM90100, TM90200, TM90300, TM90400, TM90500, TM90600, TM90700, TM90800, TM90900, TM91000, TM91100, TM91200, TM91300, TM91400, TM91500, TM91600, TM91700, TM91800, TM91900, TM92000, TM92100, TM92200, TM92300, TM92400, TM92500, TM92600, TM92700, TM92800, TM92900, TM93000, TM93100, TM93200, TM93300, TM93400, TM93500, TM93600, TM93700, TM93800, TM93900, TM94000, TM94100, TM94200, TM94300, TM94400, TM94500, TM94600, TM94700, TM94800, TM94900, TM95000, TM95100, TM95200, TM95300, TM95400, TM95500, TM95600, TM95700, TM95800, TM95900, TM96000, TM96100, TM96200, TM96300, TM96400, TM96500, TM96600, TM96700, TM96800, TM96900, TM97000, TM97100, TM97200, TM97300, TM97400, TM97500, TM97600, TM97700, TM97800, TM97900, TM98000, TM98100, TM98200, TM98300, TM98400, TM98500, TM98600, TM98700, TM98800, TM98900, TM99000, TM99100, TM99200, TM99300, TM99400, TM99500, TM99600, TM99700, TM99800, TM99900, TM100000, TM100100, TM100200, TM100300, TM100400, TM100500, TM100600, TM100700, TM100800, TM100900, TM101000, TM101100, TM101200, TM101300, TM101400, TM101500, TM101600, TM101700, TM101800, TM101900, TM102000, TM102100, TM102200, TM102300, TM102400, TM102500, TM102600, TM102700, TM102800, TM102900, TM103000, TM103100, TM103200, TM103300, TM103400, TM103500, TM103600, TM103700, TM103800, TM103900, TM104000, TM104100, TM104200, TM104300, TM104400, TM104500, TM104600, TM104700, TM104800, TM104900, TM105000, TM105100, TM105200, TM105300, TM105400, TM105500, TM105600, TM105700, TM105800, TM105900, TM106000, TM106100, TM106200, TM106300, TM106400, TM106500, TM106600, TM106700, TM106800, TM106900, TM107000, TM107100, TM107200, TM107300, TM107400, TM107500, TM107600, TM107700, TM107800, TM107900, TM108000, TM108100, TM108200, TM108300, TM108400, TM108500, TM108600, TM108700, TM108800, TM108900, TM109000, TM109100, TM109200, TM109300, TM109400, TM109500, TM109600, TM109700, TM109800, TM109900, TM110000, TM110100, TM110200, TM110300, TM110400, TM110500, TM110600, TM110700, TM110800, TM110900, TM111000, TM111100, TM111200, TM111300, TM111400, TM111500, TM111600, TM111700, TM111800, TM111900, TM112000, TM112100, TM112200, TM112300, TM112400, TM112500, TM112600, TM112700, TM112800, TM112900, TM113000, TM113100, TM113200, TM113300, TM113400, TM113500, TM113600, TM113700, TM113800, TM113900, TM114000, TM114100, TM114200, TM114300, TM114400, TM114500, TM114600, TM114700, TM114800, TM114900, TM115000, TM115100, TM115200, TM115300, TM115400, TM115500, TM115600, TM115700, TM115800, TM115900, TM116000, TM116100, TM116200, TM116300, TM116400, TM116500, TM116600, TM116700, TM116800, TM116900, TM117000, TM117100, TM117200, TM117300, TM117400, TM117500, TM117600, TM117700, TM117800, TM117900, TM118000, TM118100, TM118200, TM118300, TM118400, TM118500, TM118600, TM118700, TM118800, TM118900, TM119000, TM119100, TM119200, TM119300, TM119400, TM119500, TM119600, TM119700, TM119800, TM119900, TM120000, TM120100, TM120200, TM120300, TM120400, TM120500, TM120600, TM120700, TM120800, TM120900, TM121000, TM121100, TM121200, TM121300, TM121400, TM121500, TM121600, TM121700, TM121800, TM121900, TM122000, TM122100, TM122200, TM122300, TM122400, TM122500, TM122600, TM122700, TM122800, TM122900, TM123000, TM123100, TM123200, TM123300, TM123400, TM123500, TM123600, TM123700, TM123800, TM123900, TM124000, TM124100, TM124200, TM124300, TM124400, TM124500, TM124600, TM124700, TM124800, TM124900, TM125000, TM125100, TM125200, TM125300, TM125400, TM125500, TM125600, TM125700, TM125800, TM125900, TM126000, TM126100, TM126200, TM126300, TM126400, TM126500, TM126600, TM126700, TM126800, TM126900, TM127000, TM127100, TM127200, TM127300, TM127400, TM127500, TM127600, TM127700, TM127800, TM127900, TM128000, TM128100, TM128200, TM128300, TM128400, TM128500, TM128600, TM128700, TM128800, TM128900, TM129000, TM129100, TM129200, TM129300, TM129400, TM129500, TM129600, TM129700, TM129800, TM129900, TM130000, TM130100, TM130200, TM130300, TM130400, TM130500, TM130600, TM130700, TM130800, TM130900, TM131000, TM131100, TM131200, TM131300, TM131400, TM131500, TM131600, TM131700, TM131800, TM131900, TM132000, TM132100, TM132200, TM132300, TM132400, TM132500, TM132600, TM132700, TM132800, TM132900, TM133000, TM133100, TM133200, TM133300, TM133400, TM133500, TM133600, TM133700, TM133800, TM133900, TM134000, TM134100, TM134200, TM134300, TM134400, TM134500, TM134600, TM134700, TM134800, TM134900, TM135000, TM135100, TM135200, TM135300, TM135400, TM135500, TM135600, TM135700, TM135800, TM135900, TM136000, TM136100, TM136200, TM136300, TM136400, TM136500, TM136600, TM136700, TM136800, TM136900, TM137000, TM137100, TM137200, TM137300, TM137400, TM137500, TM137600, TM137700, TM137800, TM137900, TM138000, TM138100, TM138200, TM138300, TM138400, TM138500, TM138600, TM138700, TM138800, TM138900, TM139000, TM139100, TM139200, TM139300, TM139400, TM139500, TM139600, TM139700, TM139800, TM139900, TM140000, TM140100, TM140200, TM140300, TM140400, TM140500, TM140600, TM140700, TM140800, TM140900, TM141000, TM141100, TM141200, TM141300, TM141400, TM141500, TM141600, TM141700, TM141800, TM141900, TM142000, TM142100, TM142200, TM142300, TM142400, TM142500, TM142600, TM142700, TM142800, TM142900, TM143000, TM143100, TM143200, TM143300, TM143400, TM143500, TM143600, TM143700, TM143800, TM143900, TM144000, TM144100, TM144200, TM144300, TM144400, TM144500, TM144600, TM144700, TM144800, TM144900, TM145000, TM145100, TM145200, TM145300, TM145400, TM145500, TM145600,

Gyro Simulation Service

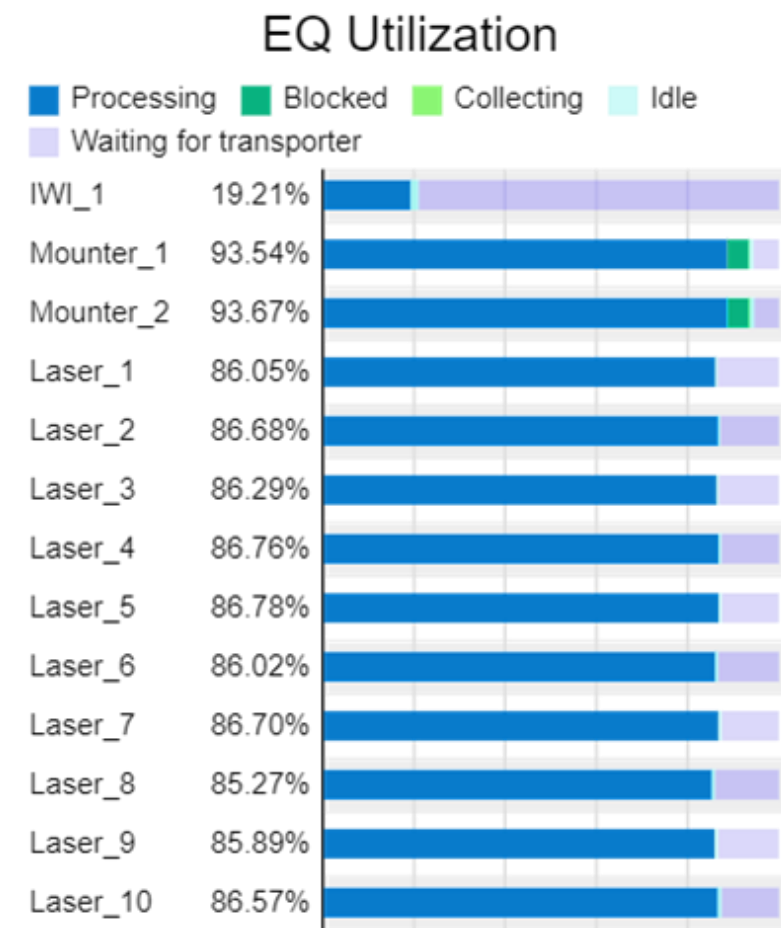
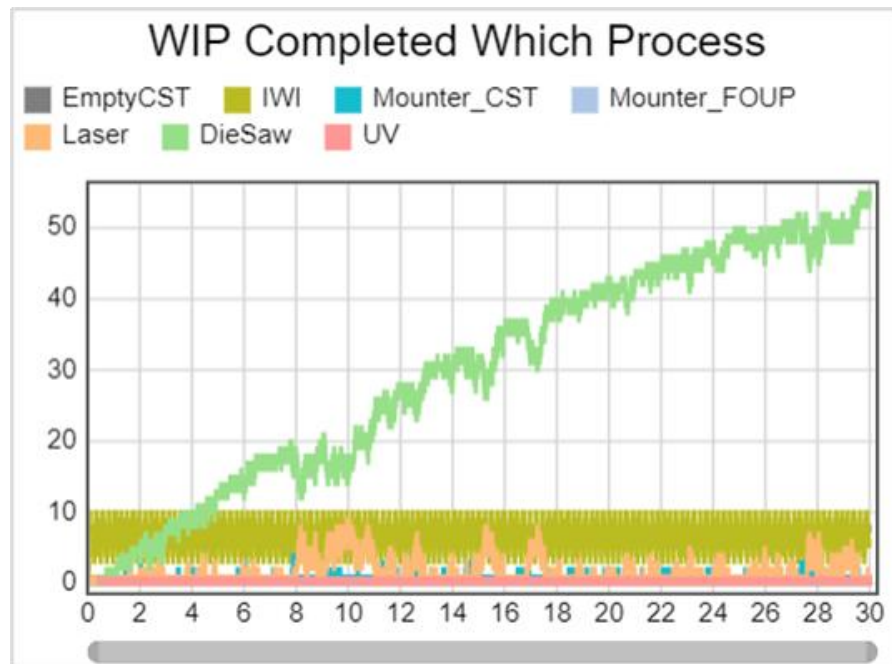
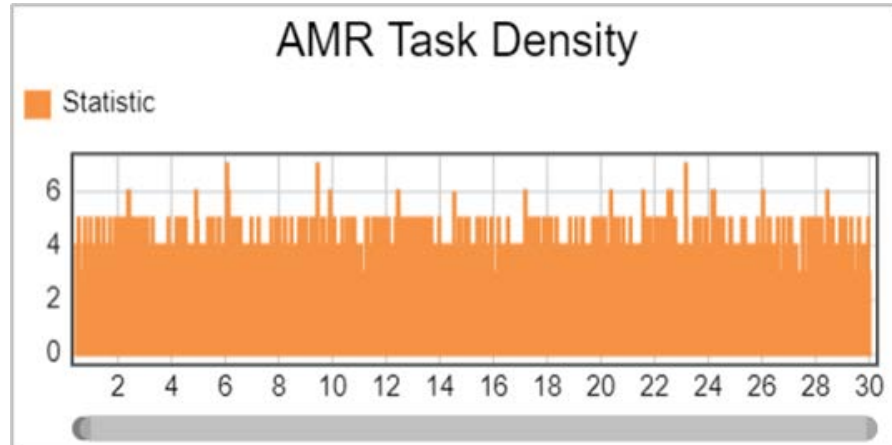
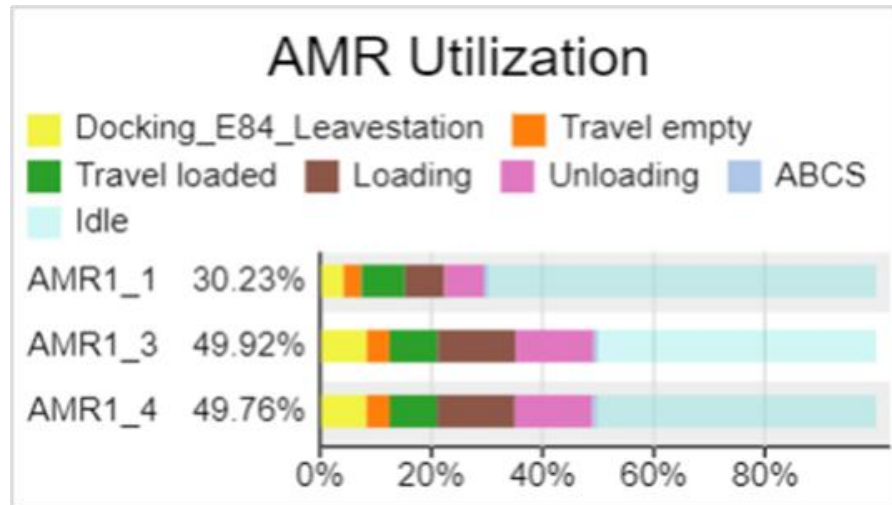

- **Dynamic Simulation System Analysis –**
Precise data evaluation/Project effect quantification
- **AMR Analysis –**
AMR operation rate/Number of tasks/Average transportation volume
- **E-RACK Analysis –**
Real-time storage volume/Equipment utilization rate/Average storage count
- **Equipment Analysis –**
Equipment operation rate/Production capacity/Cycle runs



Gyrobot Type AMRA 04

FOUP/FOSB (4 units storage)
8"/12" Metal CST 4-IN-1



JEDEC TRAY BUNDLE
(12 units storage)



8" OPEN CST
(4 units storage)

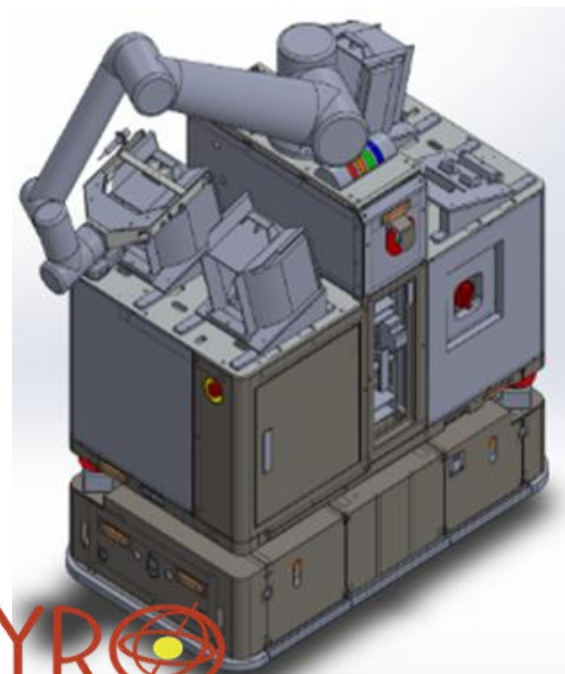

MAGAZINE
(6 units storage)



8" SMIF
(8 units storage)



AMRA04-TM14 L4

SLAM-type AMR

- Mecanum Wheels
- Support both left & right side docking 4 carrier plates supported
- RFID and PL / PS sensors (each plate) E84 communication
- SEMI-S2 compliant
- Lidar/ IR / supersonic / visual / Laser / Bumper Safety Detection
- Support Gyro AGVC controller
- Support Gyro MCS system
- **Common Platform Features**
- **Robot arm capacity up to 30KG**
- **Customizable clamps and storage space**
- **Product supply possible from 3 directions: front, left, and right**

Battery Evolution

ABCS Automatic Battery Charging Station

Item	Specifications
Model	ABCS-B4-48
Facility requirements	Power Supply: 220V 3P/4W (RSTN) 75A 15KW Air : 7kgf/cm2 5L/min
Size (mm)	1800 (L)*2700(W)*1800 (H)
Output	15KW
Charging Current (MAX)	DC57V 27A*4
Exchange Time	<3min
Charging Time (hr)	1.5 (30%~90%) (adjustable)
Safety Features	Host Safety Detection: Photoelectric smoke detector × 1 Temperature sensors × 8 Charger Safety Detection: Battery low voltage/Battery disconnection/Short circuit/Over-voltage/Overheating Battery Safety Detection: Overheating/Over-voltage/Over-current Charging Monitoring: Voltage/Current (1 SEC update for each charger and total)/Temperature Forced Safety: Abnormality: Power switch cutoff/Automatic battery disconnection

certification

SEMI S2 Certified



■ **Certificates**

- Safety: UL/EN/IEC 60950-1
- EMC: EN 55032 / 55024



Automatic Charger E84 Control Safety Charging Station

Item	Specifications
Model	Automatic Charger
Facility requirements	Power Supply: 220V Single Phase 17A
Size (mm)	720*430*360 (H)
Output	3.2KW
Charging Current (MAX)	DC57V 27A
Charging Time (hr)	1.0 (30%~90%)
Safety Features	Charging Protection: Battery low voltage/Battery disconnection/Short circuit/Over-voltage/Over-temperature Main Circuit Protection: Over-voltage/Over-current cutoff/Ground fault protection/Delayed power supply when AGV undetected/Delayed cutoff when charger inactive

certification



■ **Certificates**

- Safety: UL/EN/IEC 60950-1
- EMC: EN 55032 / 55024

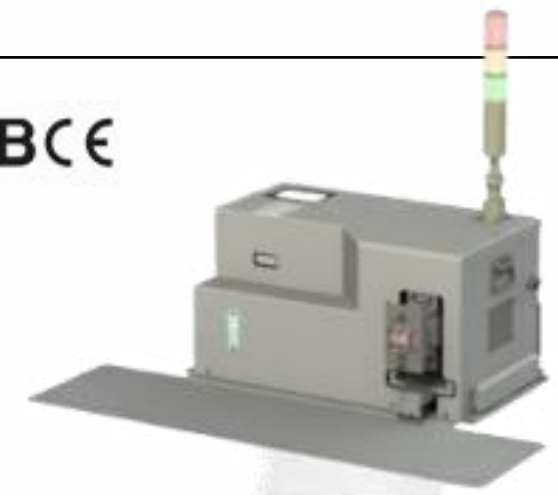

EQ automation or modification (E84, SECS/GEM, RFID)

- Support LF RFID / UHF RFID / BARCODE READER
- Support E84 SEMI standard
- Support SEMI SECS/GEM (GEM300 REPORT)

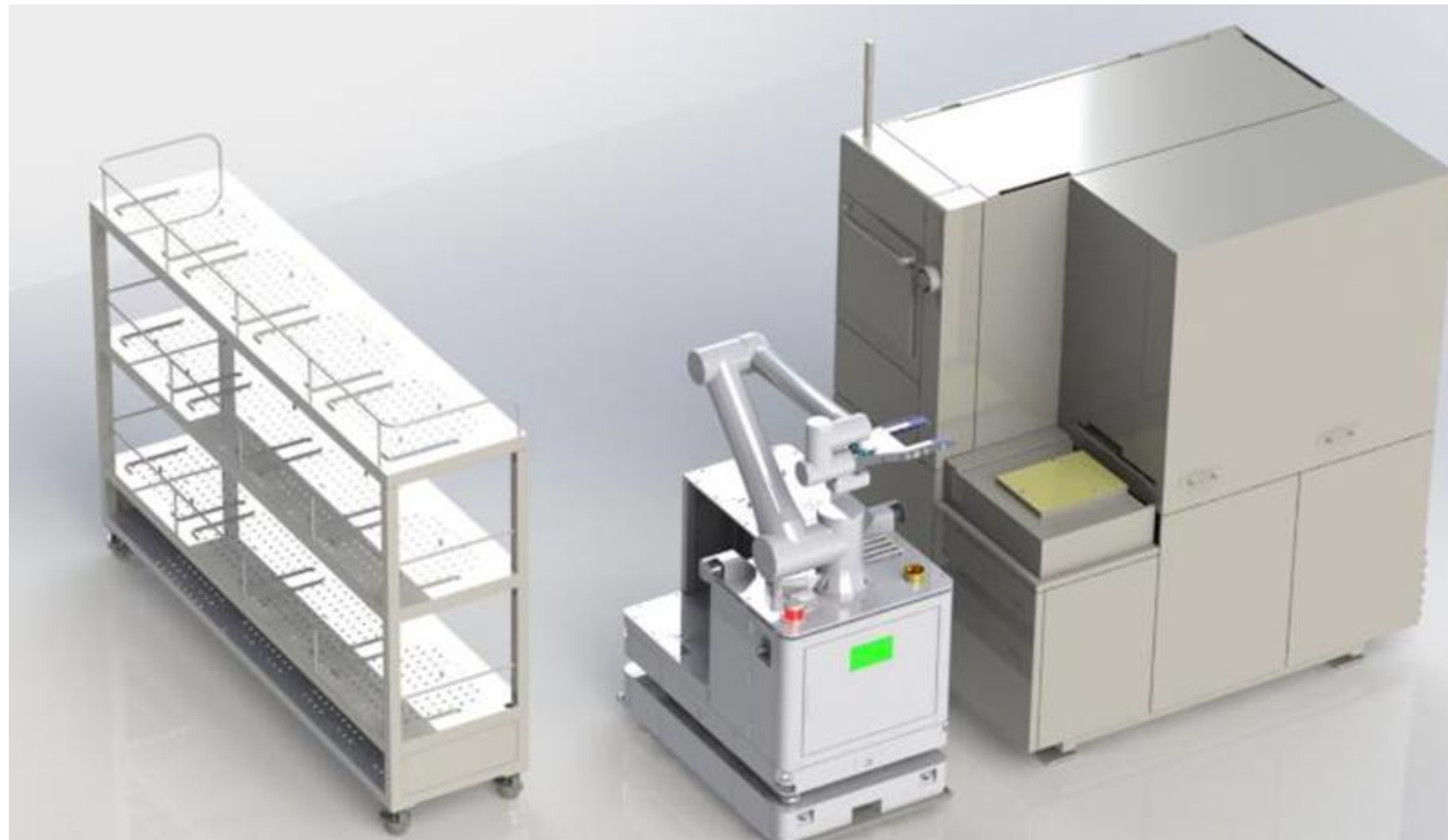

E-Rack

- LF and/or UHF RFID reader
- LED display panel
- 2 Status light, 1 Push button
- Support Mobile Robot load/unload
- SECS/GEM server
- Integrated with MHS system

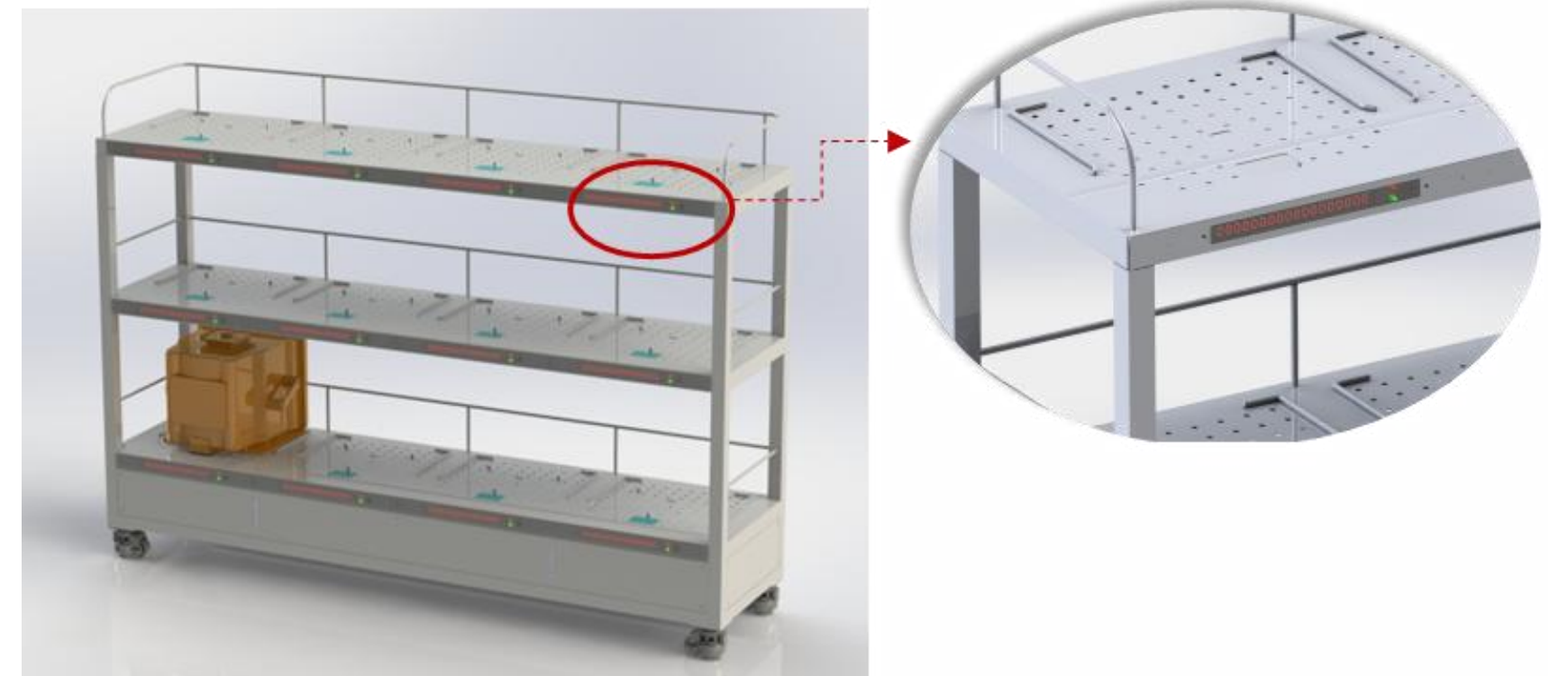

STOCKER – ZIP Type

- High capacity in small space, UPH 60
- Payload up to 20KG
- 24-hour continuous operation with MR auto-charging stand
- Dual MR PORT design with light gate protection
- MANUAL PORT automatic door safety design
- SECS E88 communication, STOCKER CONTROLLER equipped
- Easy relocation, adjustable according to line needs
- N2 Purge compatible

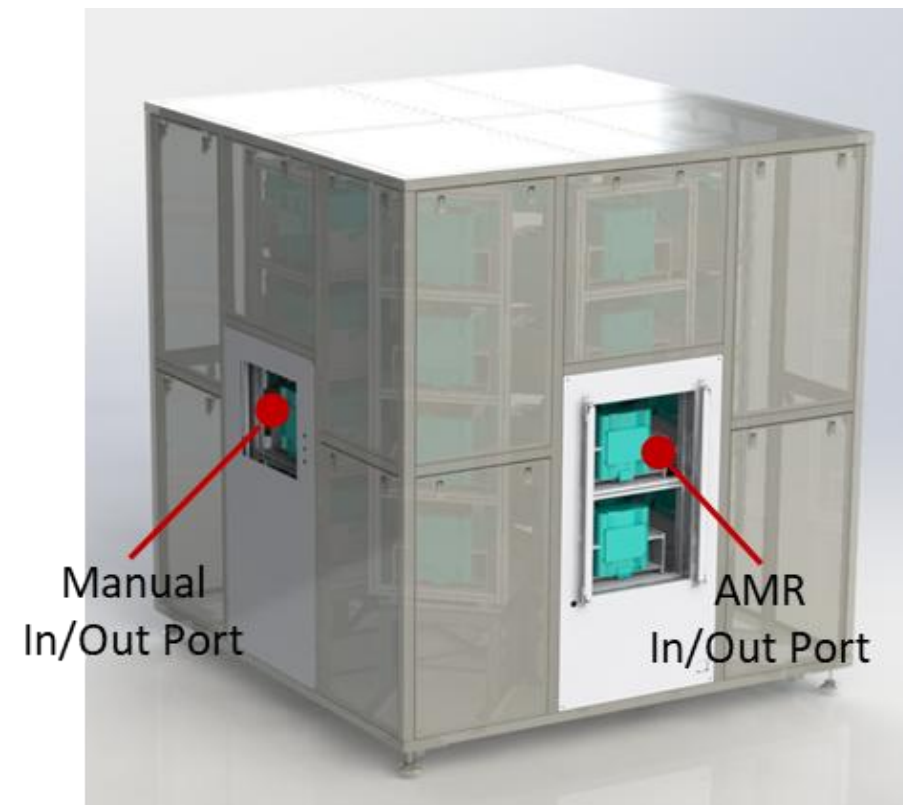

SPEC

- 1) 2.4m [28 slot + 2 AUTO + 1 MANUAL]
- 2) 2.8m [36 slot + 2 AUTO + 1 MANUAL]
- 3) 3.2m [44 slot + 2 AUTO + 1 MANUAL]

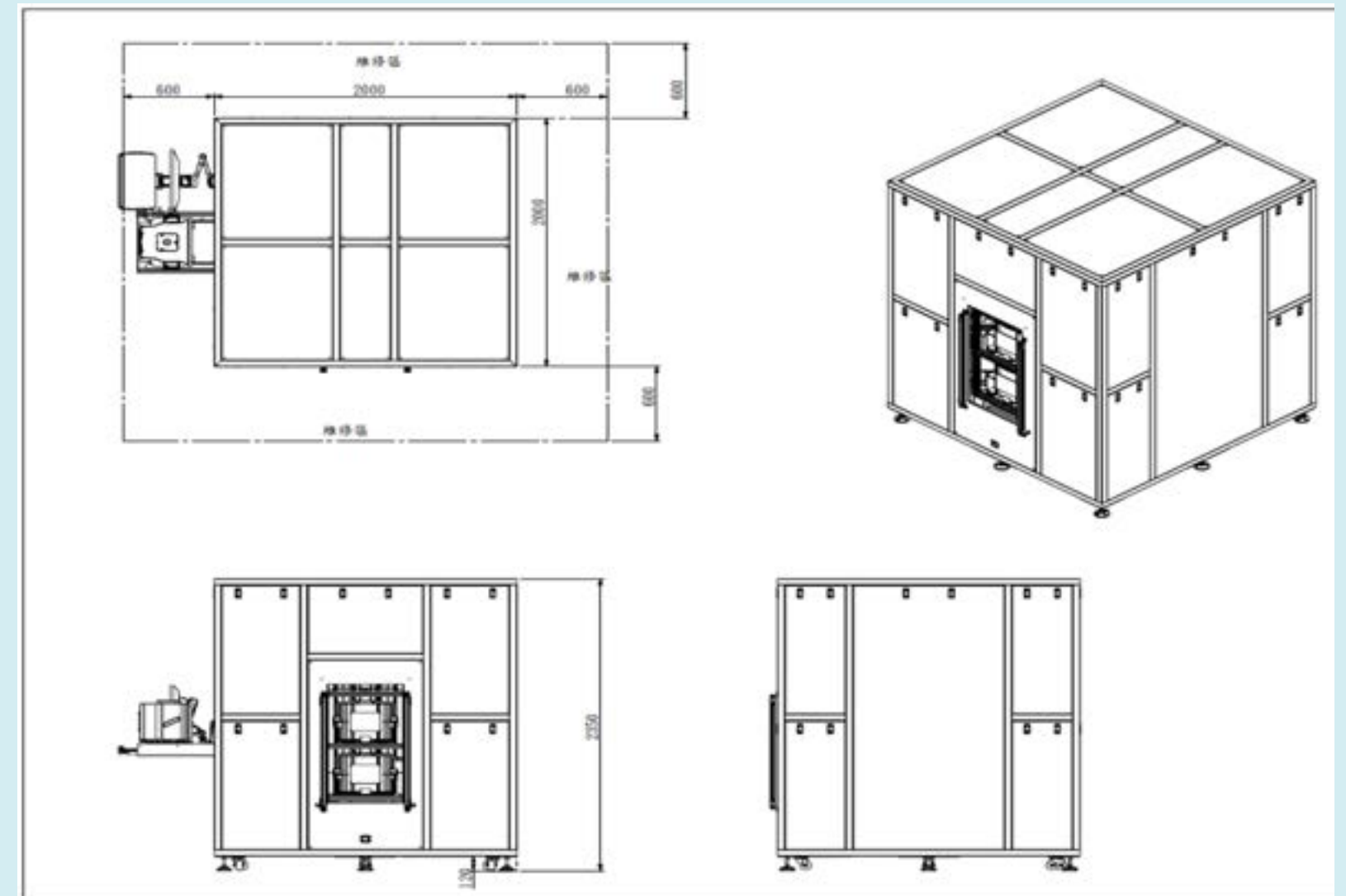

Load Port E84 add-on / upgrade

- Upgrade Load Port E84 Functions
- D-SUB 25P/RJ-11 E84 PIO sensor support
- FOUP/CST sensor input *8
- Menu/Auto/Reset/EMO input *8
- Maximum 5 controller PIO (For MR)
- RS-232 communication
- SEMI E84 standard compliant

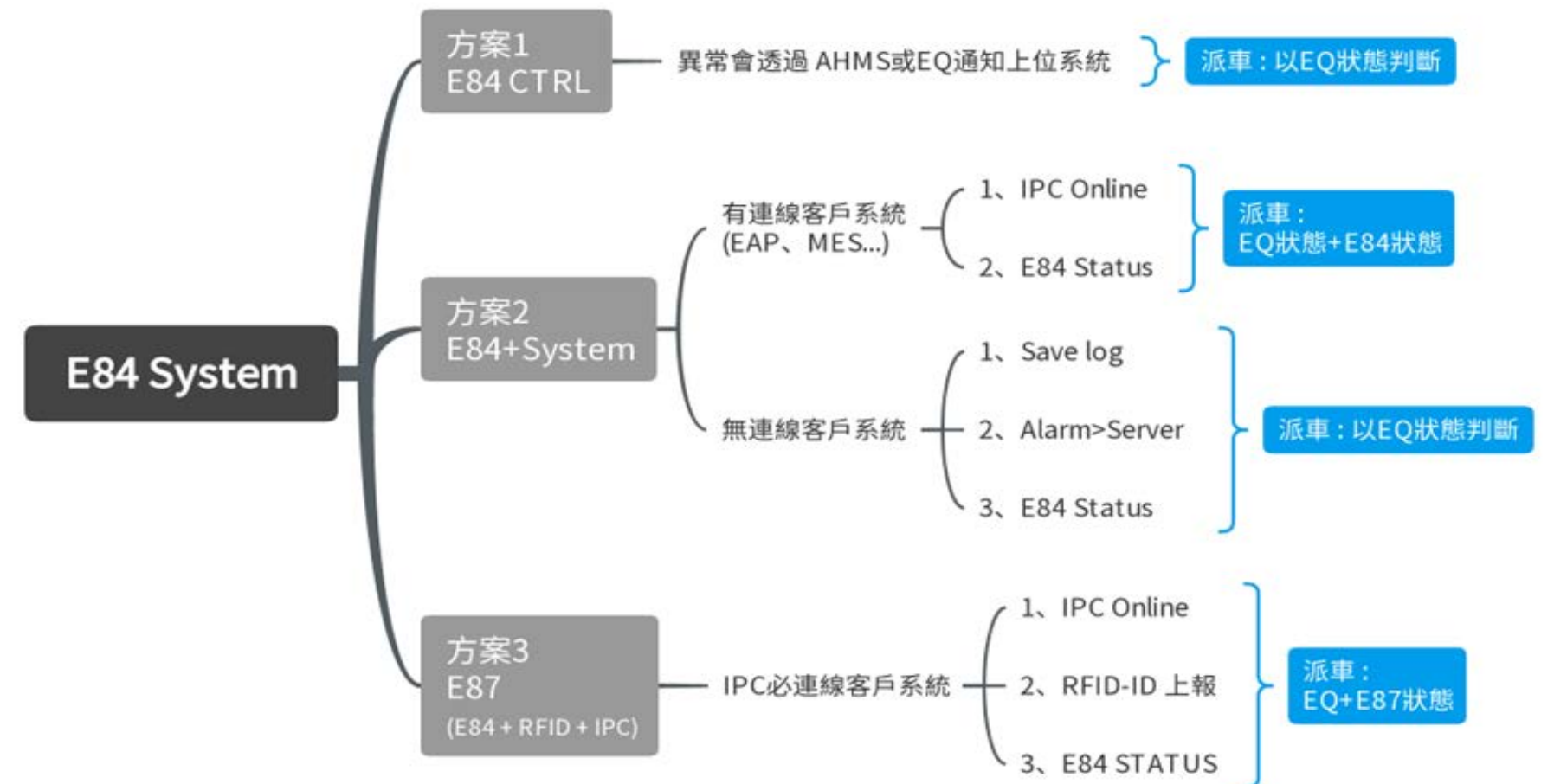
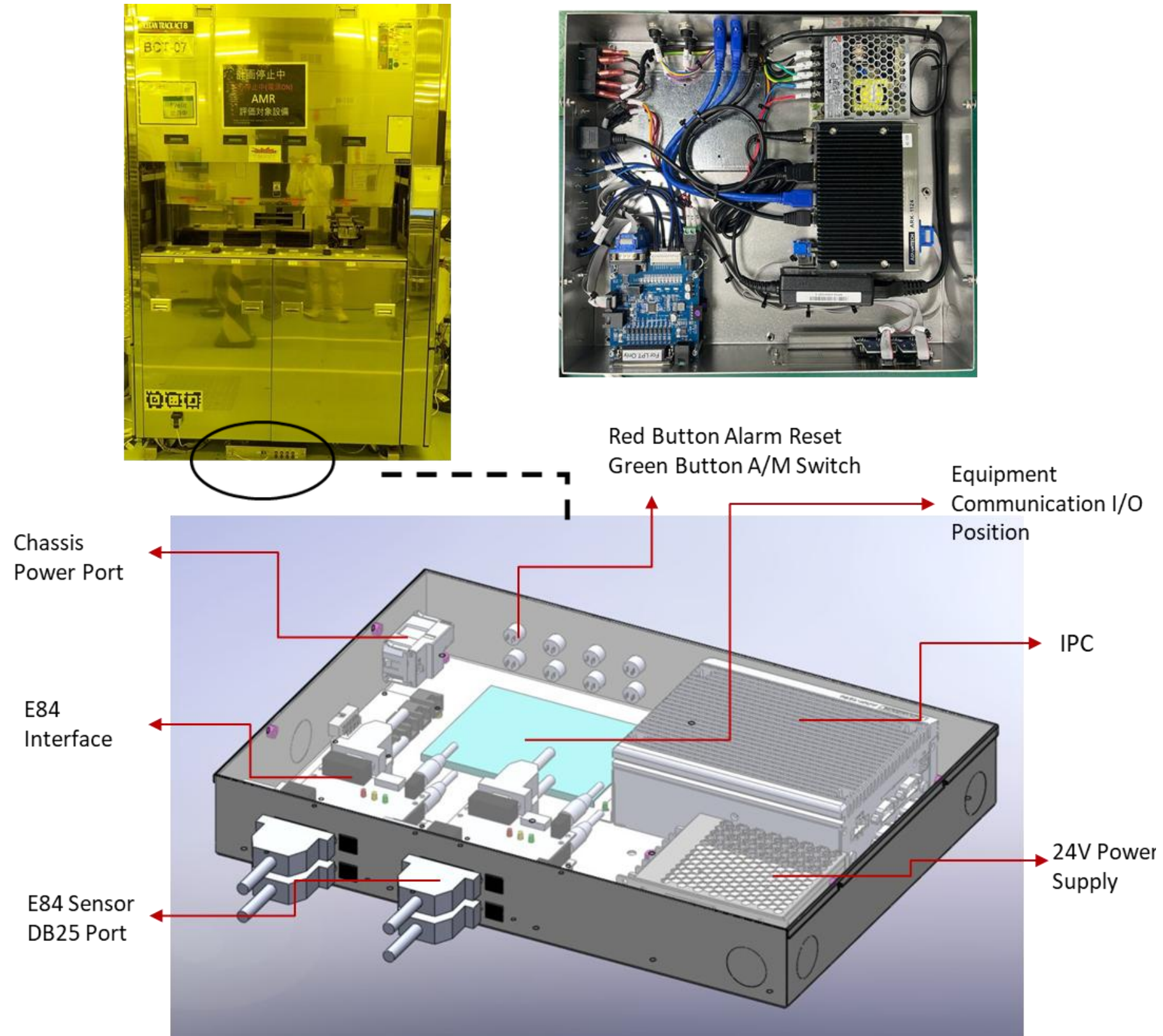

PART 3

System Introduction and Services

- **Industry 4.0 Solution**
- **System Software**



Smart Factory Integration

Industry 4.0 Solution

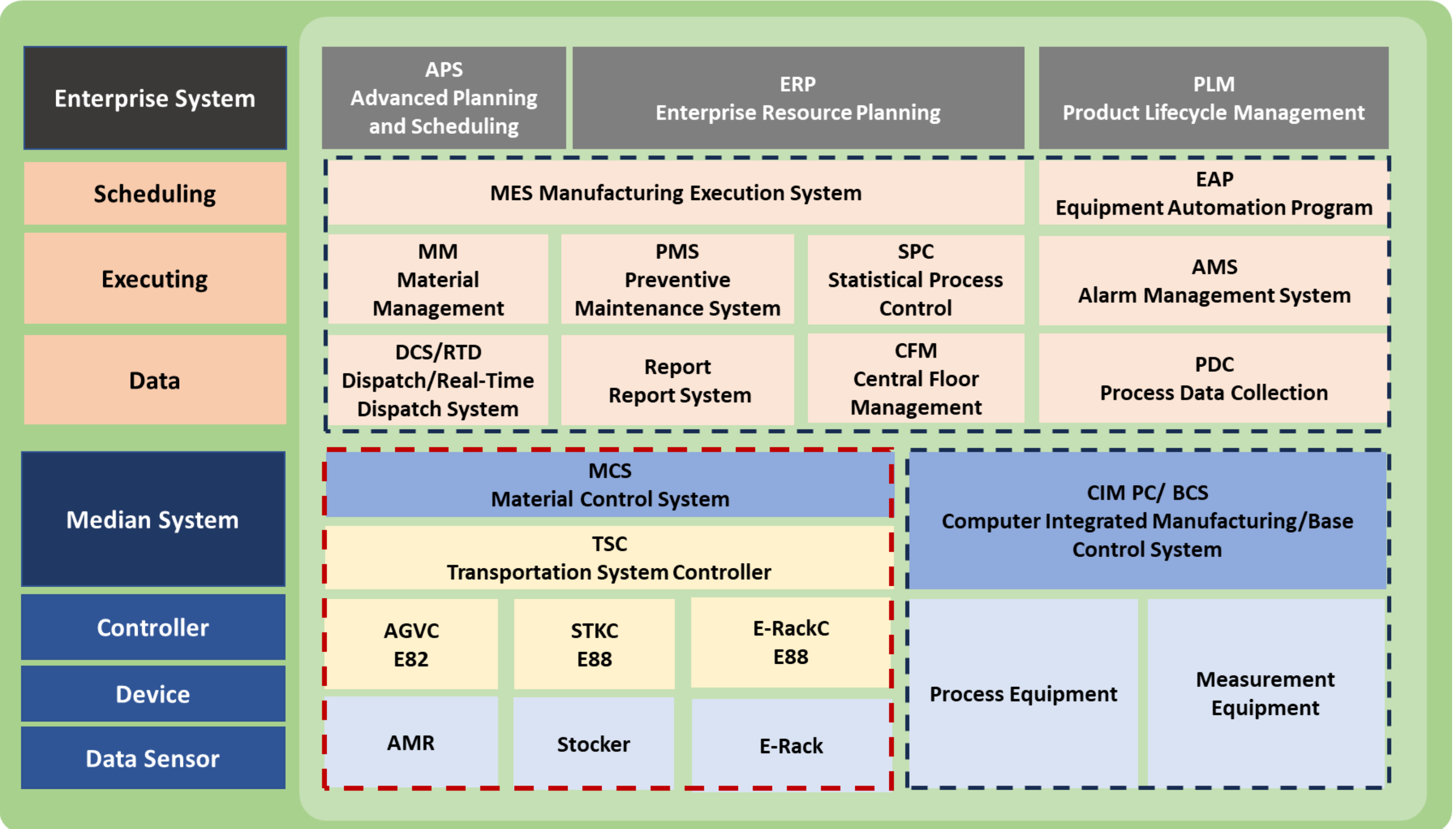

System Software

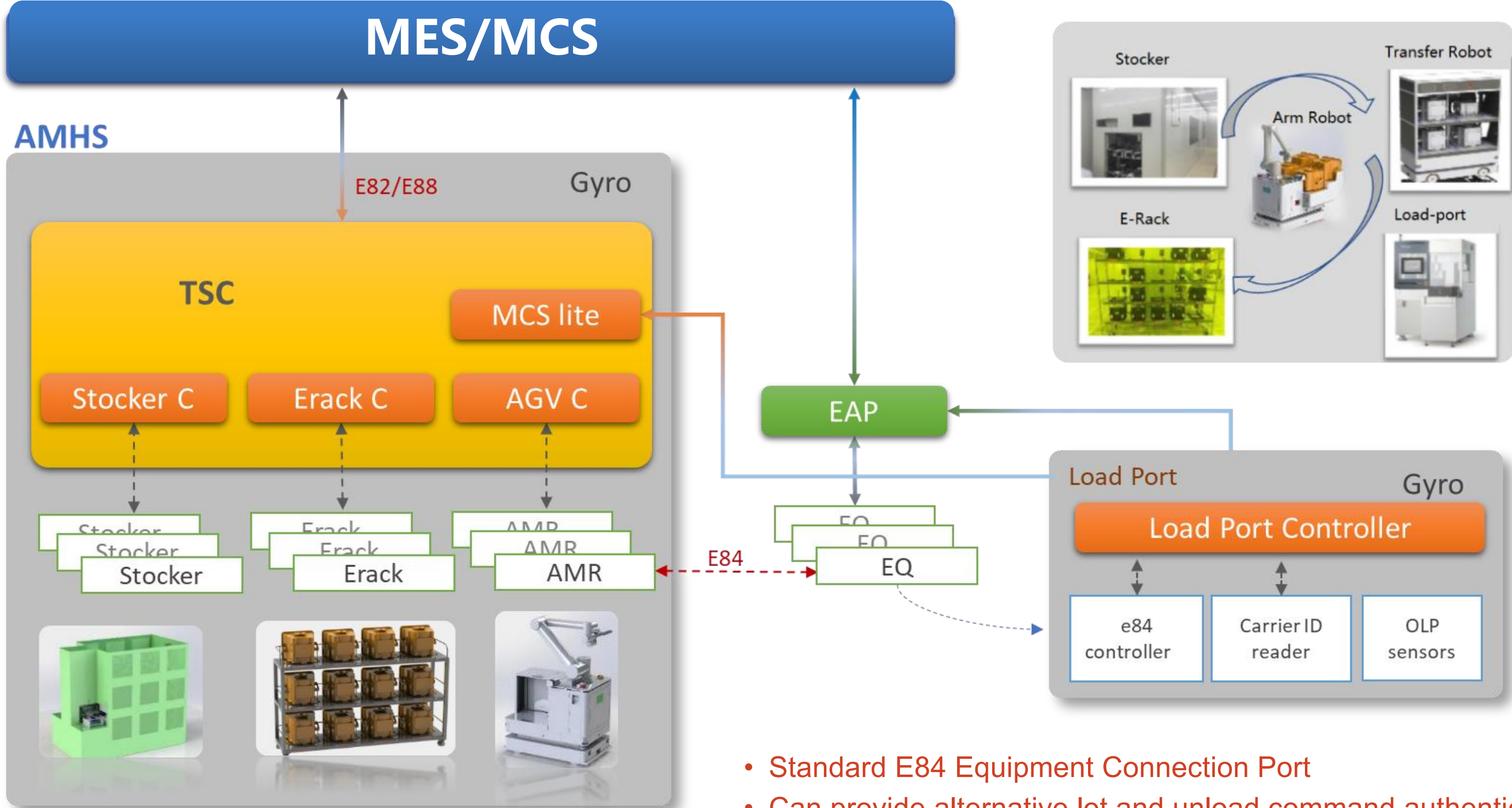

- Standard E84 Equipment Connection Port
- Can provide alternative lot and unload command authentication

System Software

TSC + MCS Lite Transfer System Controller / Material Control System - Lite



Software Features

- Multi-layer permission management
- Unified software interface
- SECS E82+/E88 interface
- Web page display
- Historical event display
- LOG file output
- Performance analysis
- Real-time lot and unload authentication
- Customizable command structure
- Multiple OLP support

System Software

TSC + MCS Lite Transfer System Controller / Material Control System - Lite

The screenshot shows the software interface for 'Current Project: Gyro Project 01 (gyro_project_01.json)'. It features a sidebar with navigation icons, a top bar with language and user settings, and a main content area. The main content area is divided into several sections: 'TSCAutoCompleted' with a 'Host Online' status; 'Vehicle: MR001' and 'Vehicle: MR002' details; 'Floor Gyro 1F'; 'Work Stations' with a grid of colored buttons representing different stations and their states; and 'eRacks' with a grid of 12 racks. Four orange callout boxes with numbers 1, 2, 3, and 4 are overlaid on the interface to highlight specific features.

eRackID	1	2	3	4	5	6	7	8	9	10	11	12
ER-A02												
ER-A03												
ER-A04												
ER-B04	GY001	GY002	GY003	GY004							GY011	GY012

Homepage Features

- 1 Main Function List
- 2 MR/AGV List
- 3 Equipment LOADPORT List
- 4 E-RACK/STOCKER List

System Software

AGV-C AGV Controller

Mechanical Wheel Movement

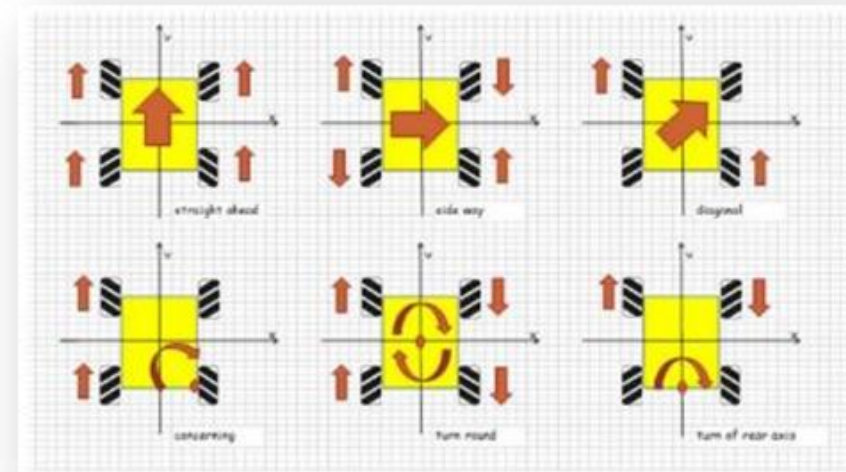

Real-time Vehicle Dynamic Page

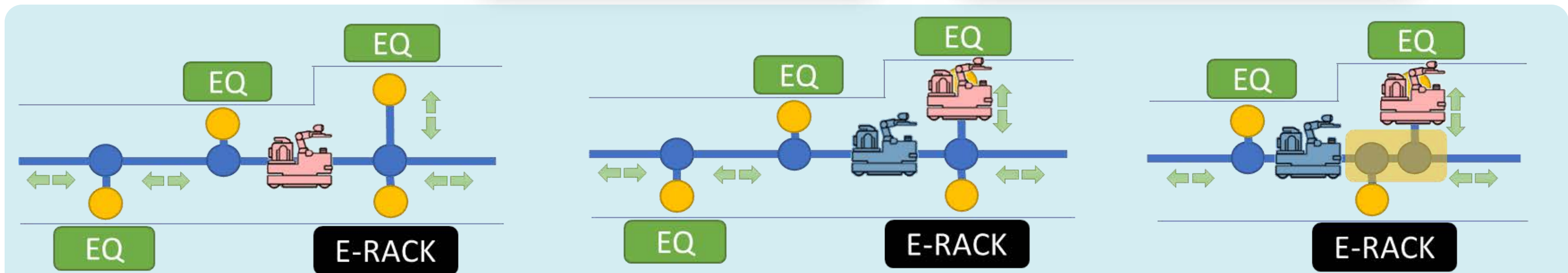
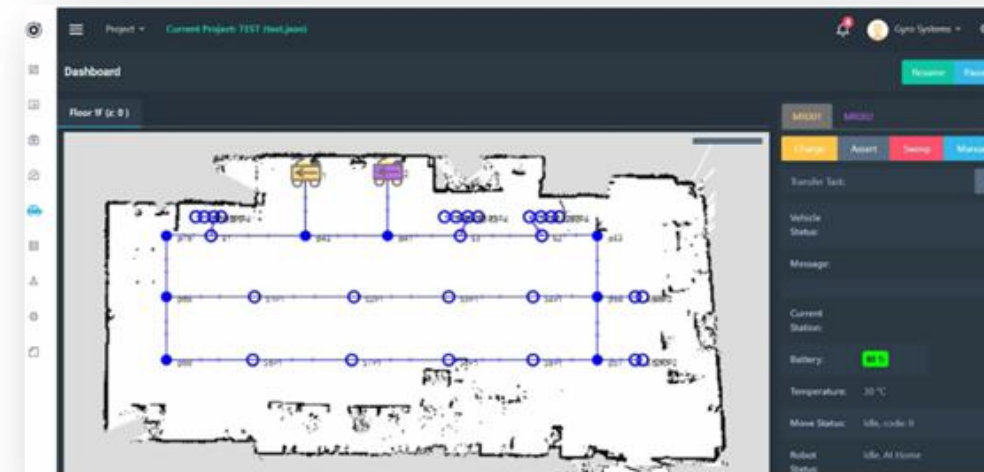

Flexible Route Features

Mechanical Wheel System
 Forward/Reverse, Lateral Movement,
 Rotation 360-degree movement capability

Traffic Management

Intersection stops
 Pre-vehicle adjustment
 Vehicle overtaking
 Automatic obstacle avoidance

Grouping

Adjacent point grouping
 Enhanced traffic control logic
 Flexible traffic control strategy planning

PART 4



Product Details

- **Equipment Details**



Mobile Robot for FOUP

Standard Type

No.	ITEM	SPEC	PHOTO
1	Size(L*W*H)	1200*720*1700mm (Standard Type)	
2	Carrier Type	FOUP/FOSB 	
3	Slot position	4	
4	Wafer Level Process	12" Si Wafer Manufacturer <hr/> 12" Wafer Foundry <hr/> 12" Wafer Probing (CP) <hr/> 12" Wafer Bumping	

Mobile Robot for FOUP

Narrow Type

No.	ITEM	SPEC	PHOTO
1	Size(L*W*H)	1200*640*1700mm (Narrow Type)	
2	Carrier Type	FOUP/FOSB 	
3	Slot position	4	
4	Wafer Level Process	12" Si Wafer Manufacturer 12" Wafer Foundry 12" Wafer Probing (CP) 12" Wafer Bumping	



60 cm width
Narrow Type





72 cm width
Standard Type

Narrow Type is suitable for narrow Fab spaces

Mobile Robot for FOUP & Metal Cassette

Three in One



No.	ITEM	SPEC	PHOTO
1	Size(L*W*H)	1200*720*1700mm (Three-In-One Type)	<div style="display: flex; justify-content: space-around;"> <div style="text-align: center;"> <p>Metal Cassette</p>  </div> <div style="text-align: center;"> <p>FOUP/FOSB</p>  </div> </div>
2	Carrier Type	FOUP/FOSB 8"&12" Metal Cassette	
3	Slot position	4	
4	Wafer Level Process	12"Si Wafer Manufacturer 12" Wafer Foundry 12" Wafer Probing (CP) 12" Wafer Bumping 8"&12"WLCSP	

Metal Cassette

FOUP/FOSB



Mobile Robot for Open Cassette 4 slots

No.	ITEM	SPEC	PHOTO
1	Size(L*W*H)	1200*720*1700mm	
2	Carrier Type	8" OPEN CASSETTE 	
3	Slot position	4	
4	Wafer Level Process	8"Si Wafer Manufacturer <hr/> 8"Wafer Foundry <hr/> 8" Wafer Bumping <hr/> 8" Wafer Probing (CP)	



Mobile Robot for 8" SMIF Pod & Wafer Box



No.	ITEM	SPEC	PHOTO
1	Size(L*W*H)	1200*720*1700mm	
2	Carrier Type	8" SMIF POD	
		8" Wafer BOX	
3	Slot position	8	
4	Wafer Level Process	8"Si Wafer Manufacturer	
		8" Wafer Foundry 8" Wafer Bumping 8" Wafer Probing	



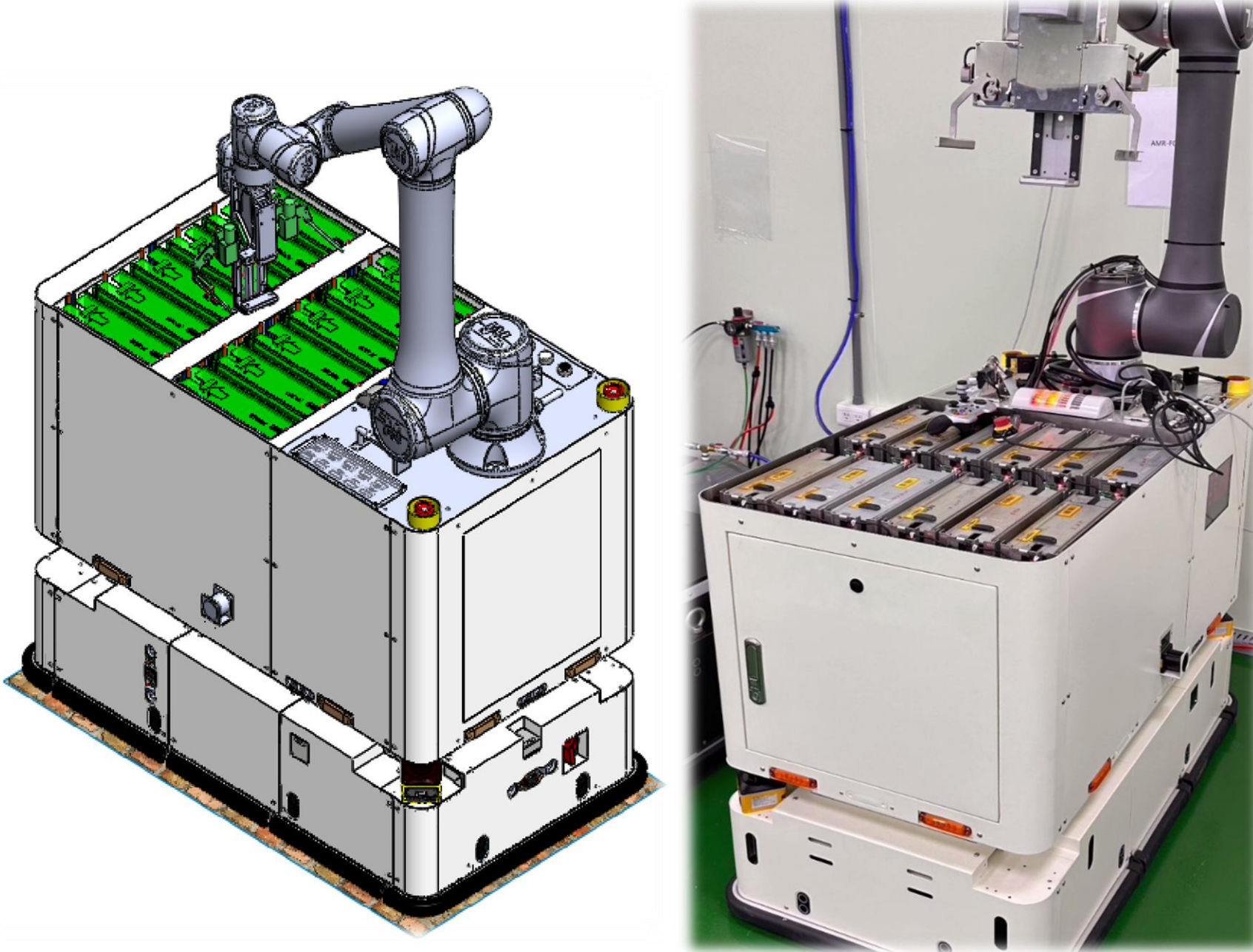

Mobile Robot for JEDEC Tray

No.	ITEM	SPEC	PHOTO
1	Size(L*W*H)	1200*720*1700mm	
2	Carrier Type	JEDEC TRAY 	
3	Slot position	6/12	
4	Process	FT Process	

Mobile Robot for MAGAZINE

No.	ITEM	SPEC	PHOTO
1	Size(L*W*H)	1200*720*1700mm	
2	Carrier Type	<p>MAGAZINE</p> 	
3	Slot position	12	
4	Process	Die attach Wire bond Molding...	

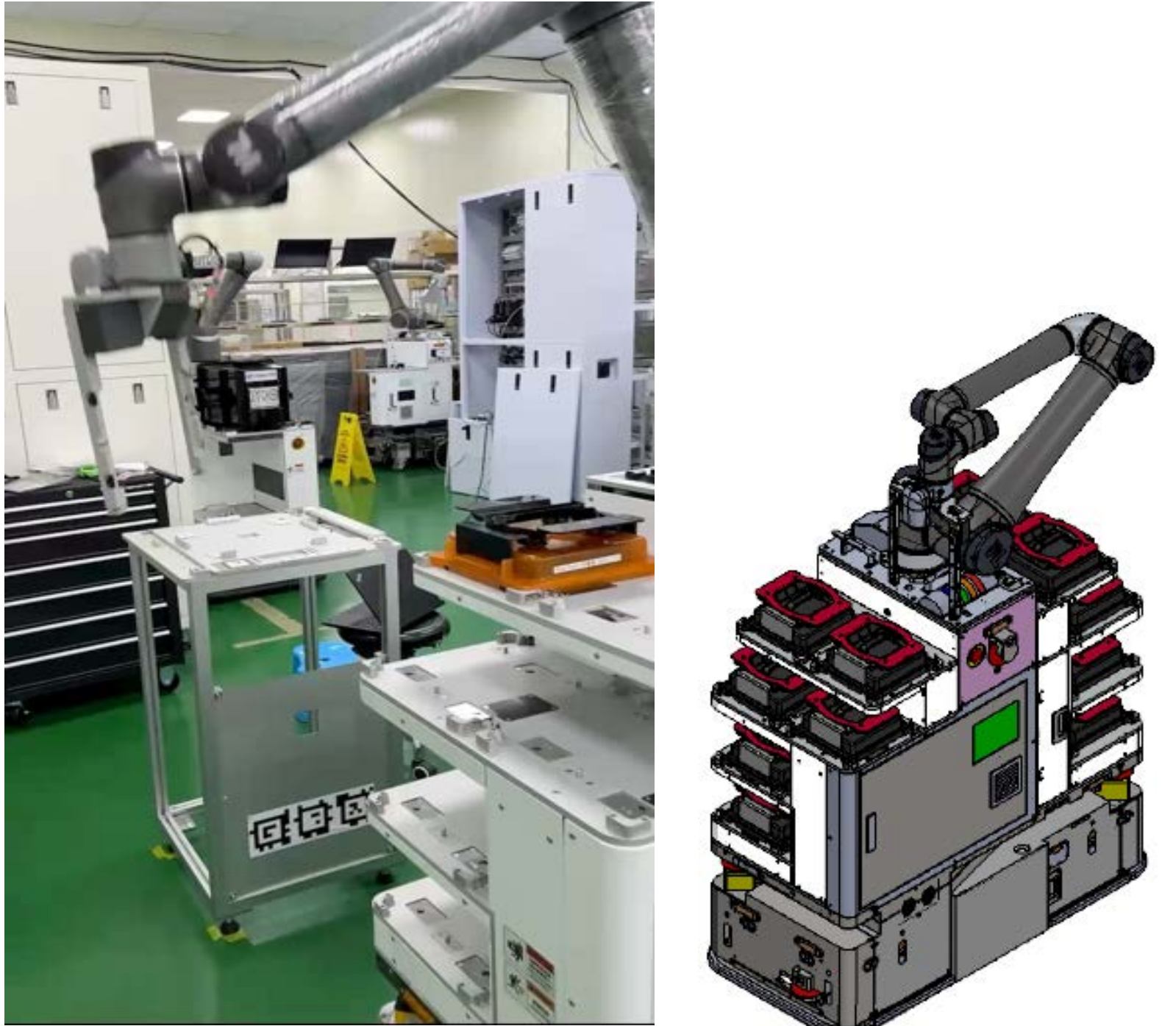
Mobile Robot for Mask SMIF Pod

No.	ITEM	SPEC	PHOTO
1	Size(L*W*H)	1200*620*1800mm	
2	Carrier Type	MASK SMIF POD 	
3	Slot position	12	
4	Process	MASK Manufacturer	

AGV Type

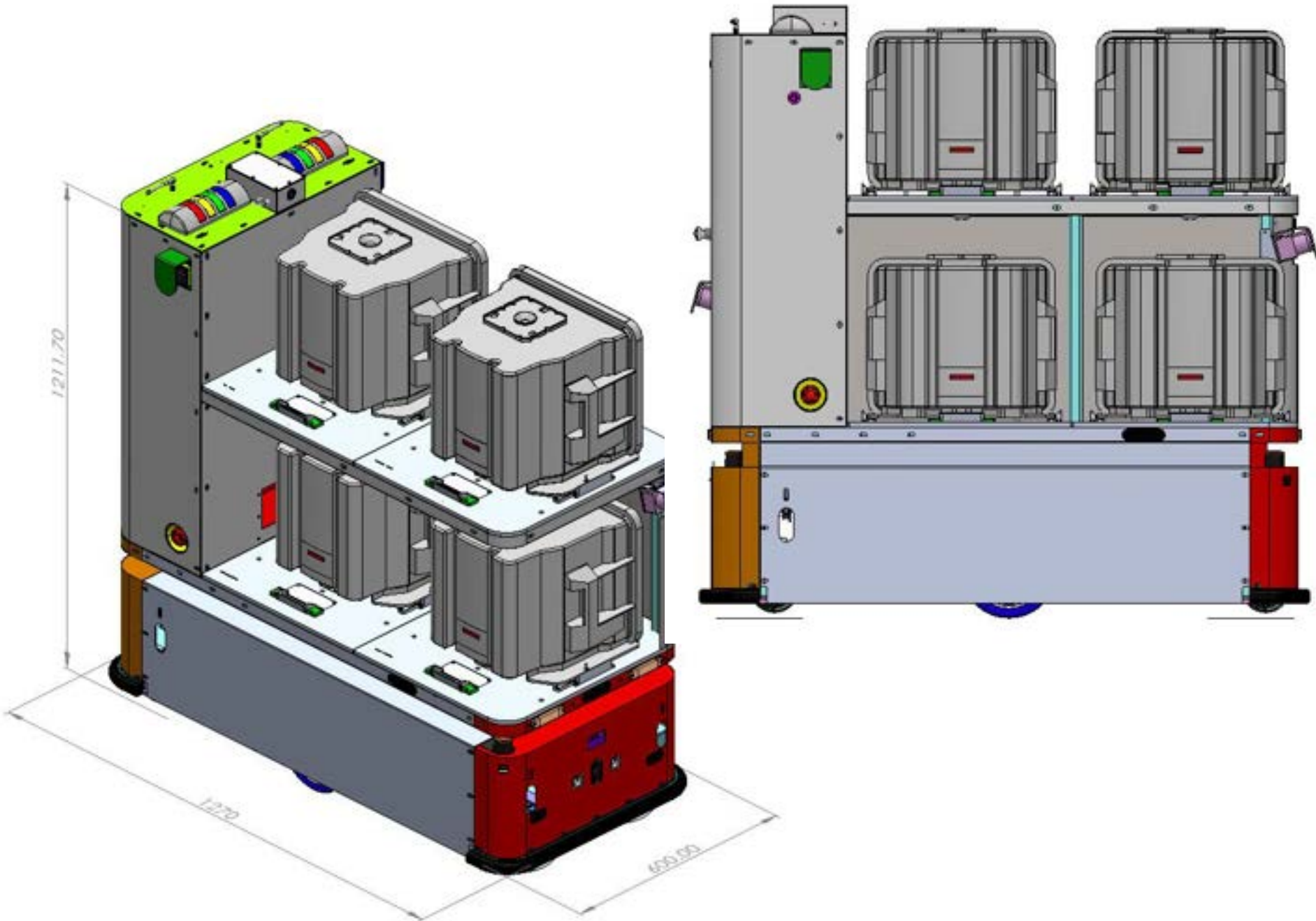
No.	ITEM	SPEC	PHOTO
1	Size(L*W*H)	1305*600*1270mm	
2	Load capacity	100KG	
3	Slot position	12"Four/8"Four...	
4	Process	Cross-building/elevator capabilities	

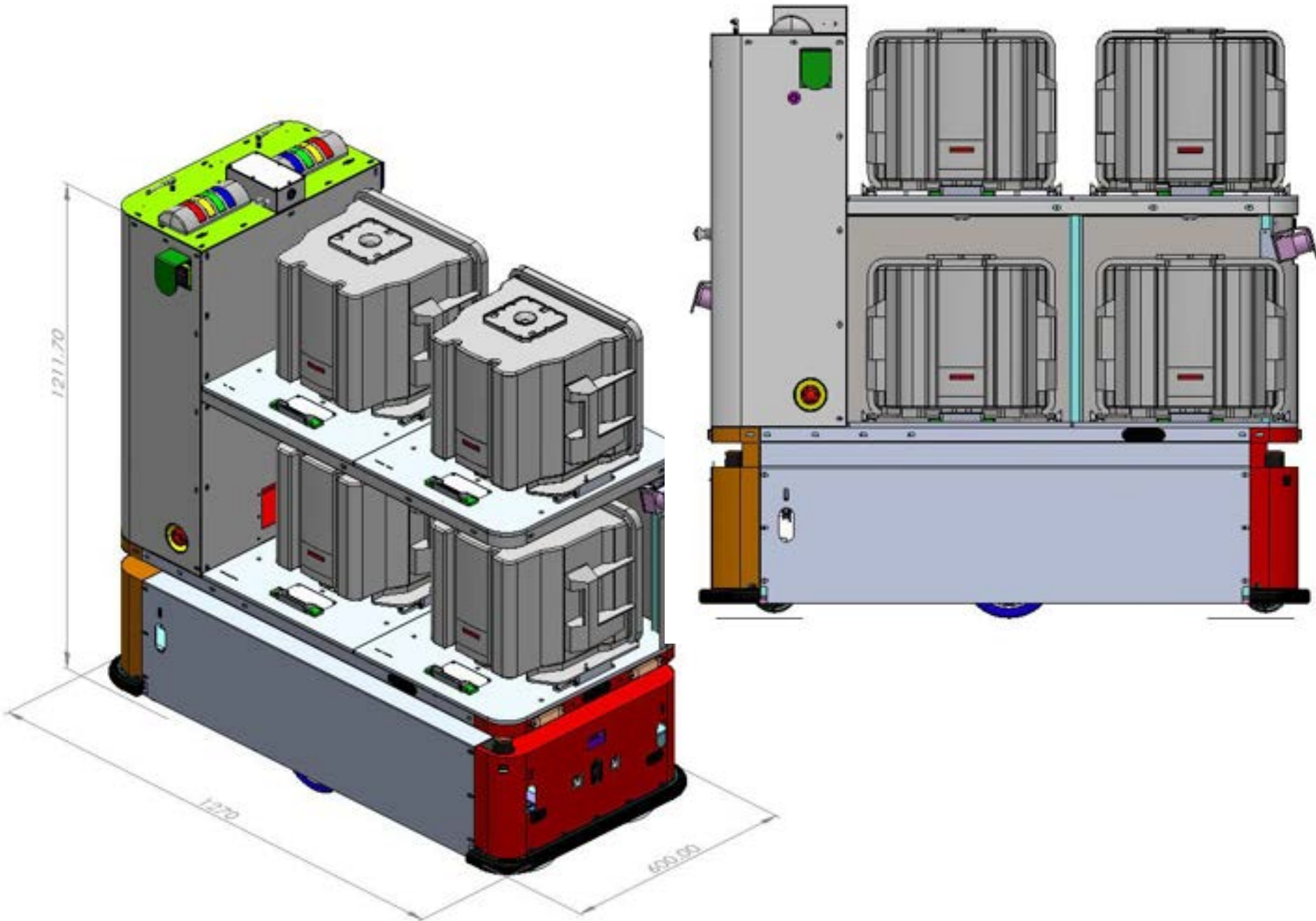



AMR with Low-base Plate for Trolley Automation

No.	ITEM	SPEC	PHOTO
1	Size(L*W*H)	1200*550*1850mm	
2	Carrier Type	Four-wheeled trolley	
3	Load capacity	300KG	
4	Process	No restrictions	

Mobile Robot for Container

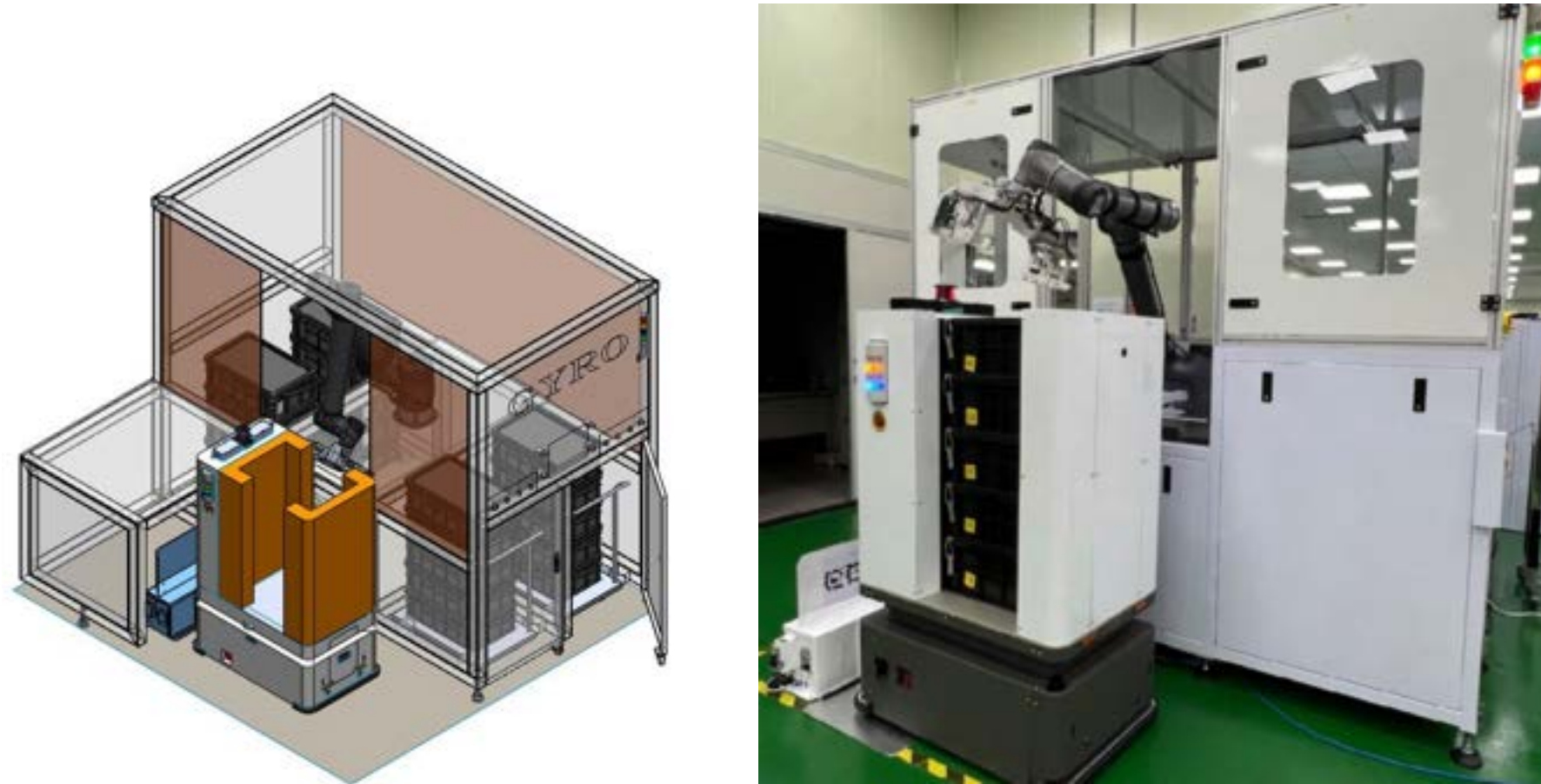
Inter-building transportation

No.	ITEM	SPEC	PHOTO
1	Size(L*W*H)	1150*670*1475mm	
2	Carrier Type		
3	Slot Position	5	
4	Process	Transport Between Buildings	

AMR for Panel FOUN Automation

No.	ITEM	SPEC	PHOTO
1	Size(L*W*H)	1150*670*1475mm	  
2	Carrier Type	Panel FOUN 	
3	Slot Position	Customizable Material Rack	
4	Process	No Restriction	

Stocker - 8" Box for Open Cassette

8 INCH E-MINI STOCKER, provide automatic and manual storage of 8-inch wafer box with cassette for **WIP** and **FG** storage. customize storage capacities base on customer demand

Features:

- Simple set up
- Plug & Play
- Compact
- User friendly HMI
- Programmable for Auto and Manual load
- SEC/GEMS readiness

Configuration:

- 8-inch wafer box Manual loader
- 8-inch Box Opener
- 3 axes motorized box transporter.
- 19 storage location
- PC based control
- E84, E88 enable

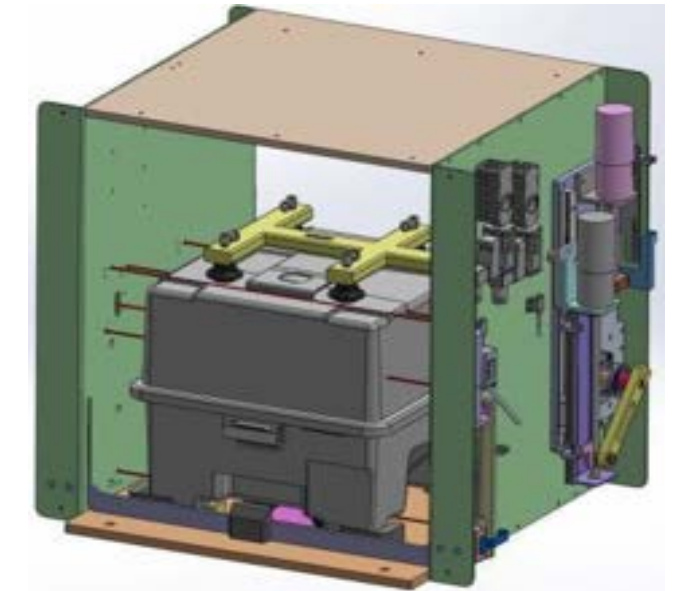
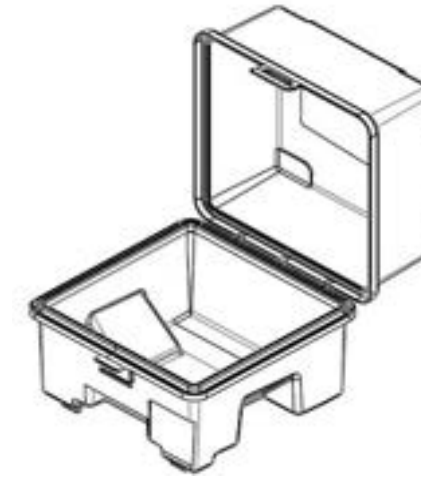

Stocker – Mini Type

- Width 1.6M, length can be customized, UPH 60
- PAYLOAD UP TO 20KG
- Side I/O PORT can be configured arbitrarily, saving space
- Compatible with MR automatic charging pile, 24hr continuous operation
- SECS E88 Communications with Stocker Controller
- MR PORT double layer design, shutter protection
- MANUAL PORT automatic door safety design
- Support N2 Purge

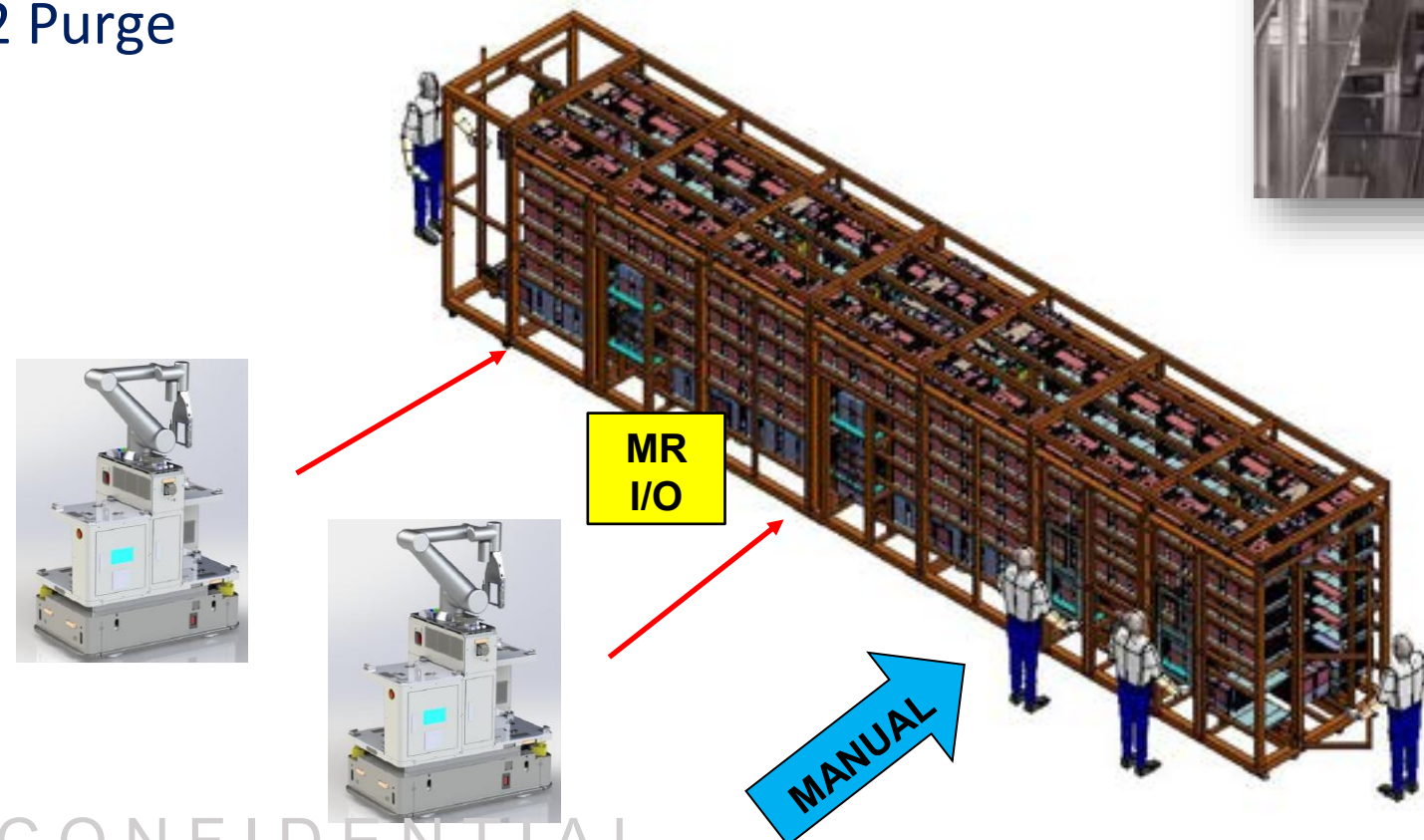
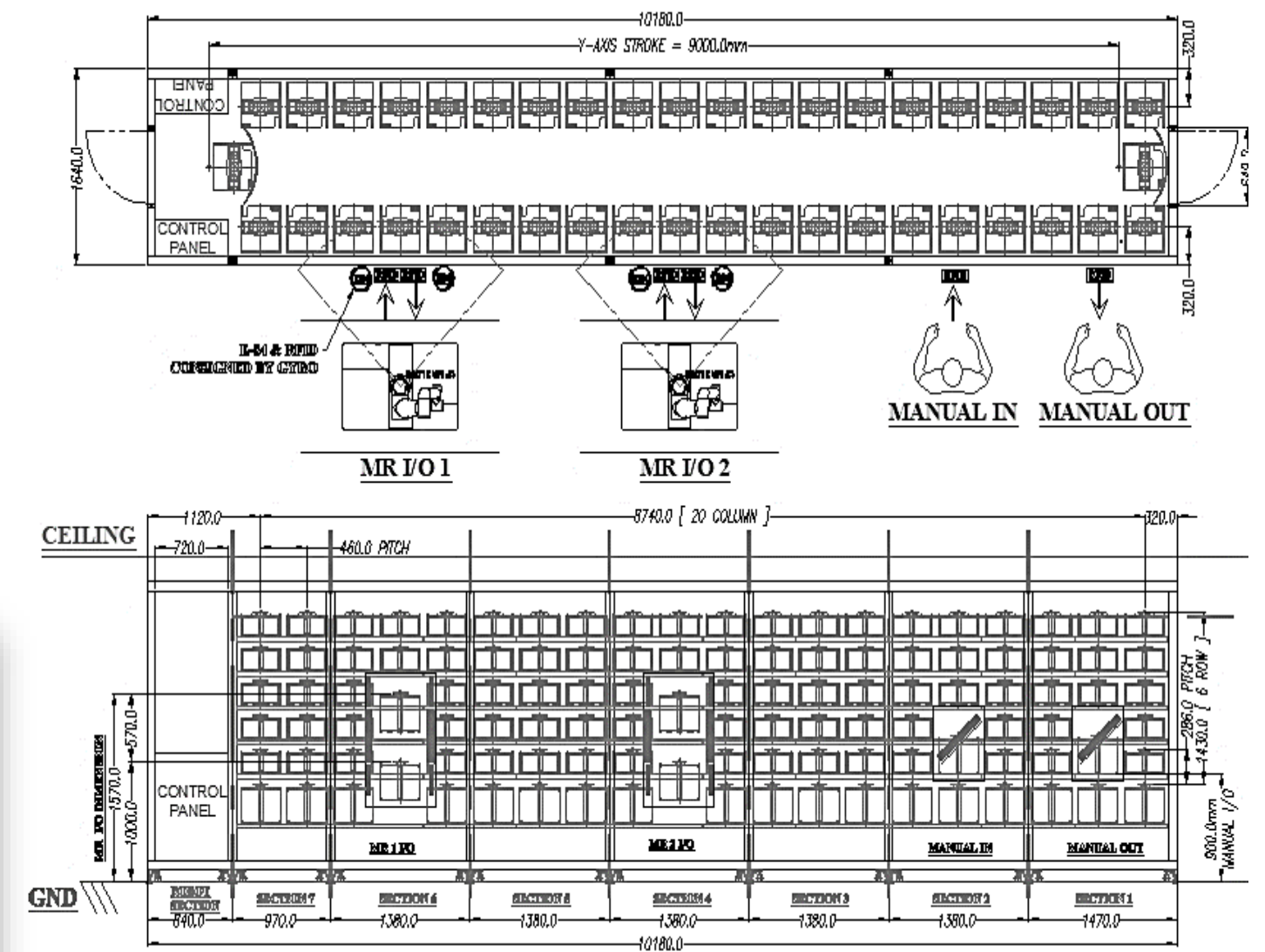

AMHS – Conveyer System

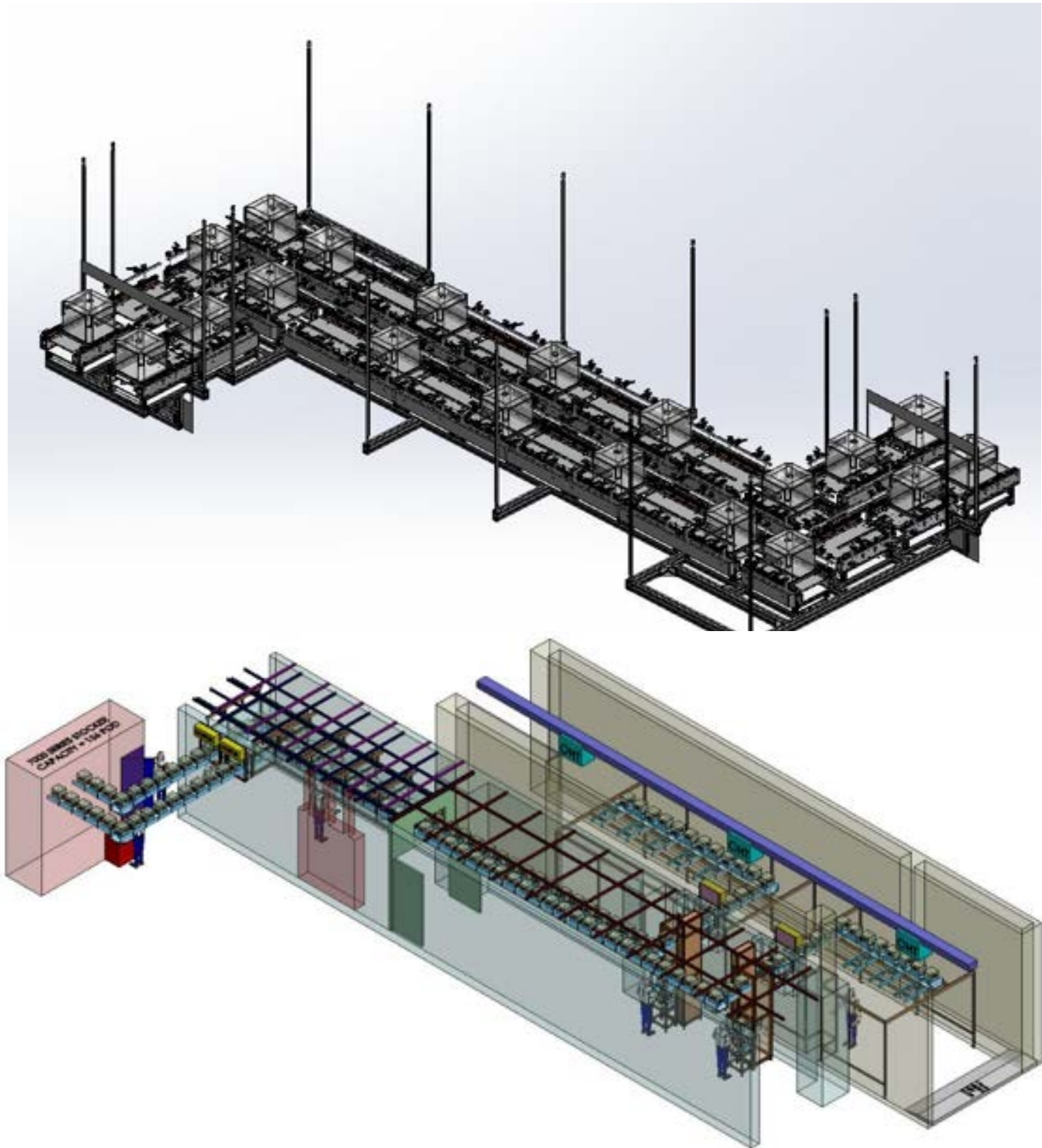



PART 5

Application and Safety

- **Application Cases**
- **Safety**

12"FOUP AMHS Application

- MCS / AGVC / E-RACK / MR / Mini-STOCKER
- Load PortwithE84sensor / E84 controller

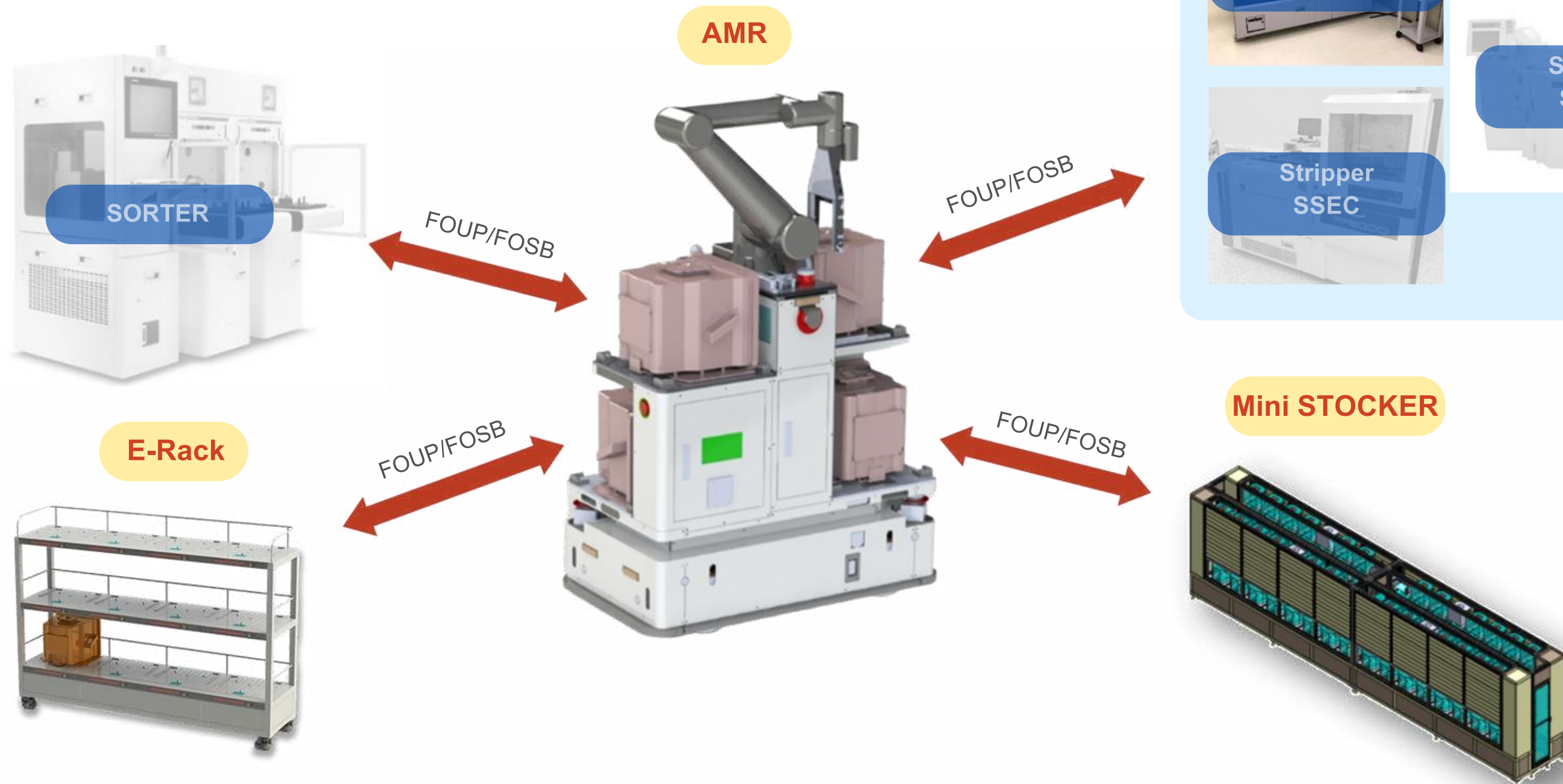

8" Open CST AMHS Application

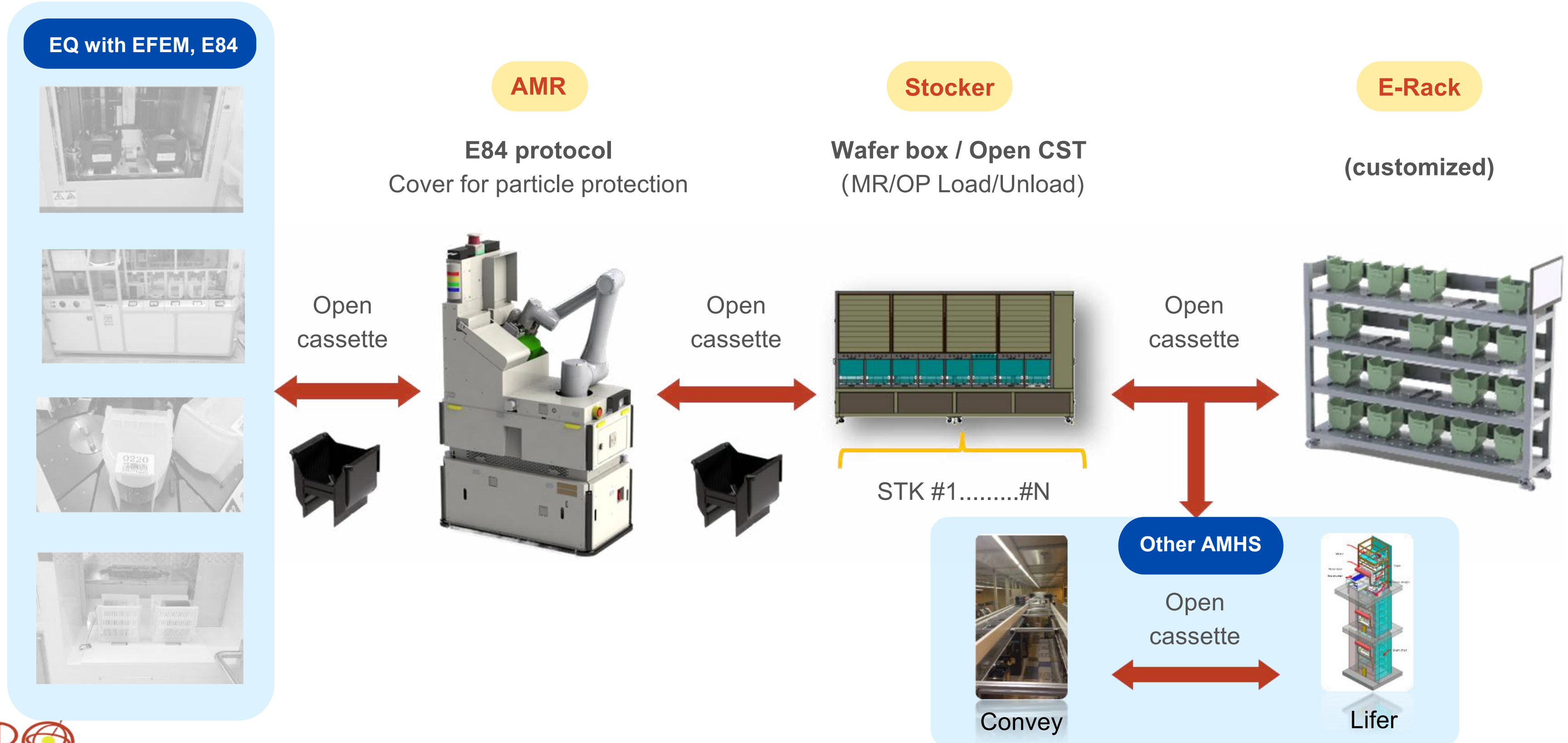

Gyro Twin Arm AMR



Smart Factory Implementation Program



Step 1

Smart Factory Consulting



- ① Vision
- ② Design Requirements

Step 2

Data Analysis

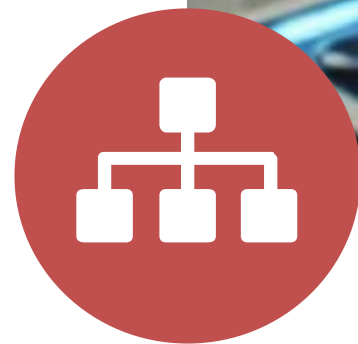

- ① Workflow Classification
- ② Equipment and Instrumentation Discussion
- ③ Equipment Transportation and Warehousing
- ④ Information System Architecture Framework

Step 3

Integrate planning and simulation



Plan an appropriate logistics equipment system based on the data analysis results.

Step 4

Project Report



- ① Investment amount
- ② Select the appropriate solution

Step 5

Project Implementation



- ① Project Team Formation
- ② Kickoff Meeting

Thank you

Smart Factory Practitioner